

1 **Digital Imaging and Communications in Medicine**
2 **(DICOM)**

3 **Sup 200 - Transformation of NCI Annotation and Image Markup**
4 **(AIM) and DICOM SR Measurement Templates**

DRAFT

5 DICOM Standards Committee - Working Group 8 - Structured Reporting

6 1300 N. 17th Street Suite 1752
7 Rosslyn
8 VA
9 22209
10 USA
11

12 Status: Final Text
13 Publication date 2017/11/20

14 This supplement is prepared pursuant to work item: 2015-12-B
15 Copyright © 2017 NEMA

Table of Contents

2	Scope and Field of Application	6
3	DICOM PS3.1. Changes	7
4	6.1. Document Structure	7
5	6.21. PS3.21: Transformations between DICOM and other Representations	7
6	DICOM PS3.16. Changes	8
7	TID 300. Measurement	8
8	TID 1419. ROI Measurements	8
9	TID 4019. CAD Algorithm Identification	9
10	TID 1003. Person Observer Identifying Attributes	9
11	D. DICOM Controlled Terminology Definitions (Normative)	10
12	DICOM PS3.21. Transformations between DICOM and other Representations	11
13	PS3.21	12
14	Notice and Disclaimer	13
15	Foreword	14
16	1. Scope and Field of Application	15
17	2. Normative and Informative References	16
18	3. Definitions	17
19	3.1. Codes and Controlled Terminology Definitions:	17
20	4. Symbols and Abbreviations	18
21	5. Conventions	19
22	A. Transformation Between AIM and DICOM SR	20
23	A.1. Scope and Field of Application	20
24	A.2. Use Cases	20
25	A.3. Structure of DICOM SR Documents	21
26	A.3.1. Header	22
27	A.3.2. Document Body	23
28	A.3.2.1. DICOM SR "Measurement Report" Template Structure	23
29	A.3.2.2. Mapping Considerations	25
30	A.3.2.3. DICOM Composite Object References	25
31	A.4. Structure of AIM Version 4 Instances	25
32	A.5. AIM v4 Structure	26
33	A.6. AIM v4 to DICOM TID 1500 Mapping	26
34	A.6.1. Mapping of Constrained AIM v4	27
35	A.6.1.1. Header	27
36	A.6.1.1.1. Mapping of DICOM Patient Module	28
37	A.6.1.1.2. Mapping of DICOM Clinical Trial Subject Module	28
38	A.6.1.1.3. Mapping of DICOM General Study Module	28
39	A.6.1.1.4. Mapping of DICOM Patient Study Module	29
40	A.6.1.1.5. Mapping of DICOM Clinical Trial Study Module	29
41	A.6.1.1.6. Mapping of DICOM SR Document Series Module	29
42	A.6.1.1.7. Mapping of DICOM Clinical Trial Series Module	30
43	A.6.1.1.8. Mapping of DICOM General Equipment Module	30
44	A.6.1.1.9. Mapping of DICOM SR Document General Module	30
45	A.6.1.1.10. Mapping of DICOM SR Document Content Module	32
46	A.6.1.1.11. Mapping of DICOM SOP Common Module	34
47	A.6.1.2. Content Tree	34
48	TID 1500. Mapping of Measurement Report	34
49	TID 1501. Mapping of Measurement Group	36
50	TID 1502. Mapping of Time Point Context	39
51	TID 1410. Mapping of Planar ROI Measurements	40
52	TID 1411. Mapping of Volumetric ROI Measurements	44
53	TID 1419. Mapping of ROI Measurements	47
54	TID 1420. Mapping of Measurements Derived From Multiple ROI Measurements	52
55	TID 300. Mapping of Measurement	53
56	TID 320. Mapping of Image or Spatial Coordinates	57
57	TID 4019. Mapping of Algorithm Identification	58
58	TID 4108. Mapping of Tracking Identifier	59

1	TID 1204. Mapping of Language of Content Item and Descendants	60
2	TID 1001. Mapping of Observation Context	60
3	TID 1002. Mapping of Observer Context	61
4	TID 1003. Mapping of Person Observer Identifying Attributes	61
5	TID 1600. Mapping of Image Library	63
6	TID 1601. Mapping of Image Library Entry	63
7	TID 1602. Mapping of Image Library Entry Descriptors	63
8	A.7. Sample Documents	67
9	A.7.1. Source AIM v4 Instance	67
10	A.7.2. Target DICOM SR "Measurement Report" (TID 1500)	71
11	A.8. Overview of Data Types	88

DRAFT

List of Figures

A.2-1. Annotation Creation and Transformation	20
A.3-1. SR Document Structure	22
A.3.2.1-1. Template Structure Summarized from PS 3.16	24
A.4-1. AIM v4 Instance Structure	26

DRAFT

List of Tables

2	TID 300. Measurement	8
3	TID 1419. ROI Measurements	8
4	TID 4019. CAD Algorithm Identification	9
5	TID 1003. Person Observer Identifying Attributes	9
6	D-1. DICOM Controlled Terminology Definitions	10
7	A.3.1-1. Transformation of DICOM SR IOD Modules	22
8	A.6.1.1.1-1. Mapping of DICOM Patient Module	28
9	A.6.1.1.3-1. Mapping of DICOM General Study Module	29
10	A.6.1.1.6-1. Mapping of DICOM SR Document Series Module	29
11	A.6.1.1.8-1. Mapping of DICOM General Equipment Module	30
12	A.6.1.1.9-1. Mapping of DICOM SR Document General Module	30
13	A.6.1.1.11-1. Mapping of DICOM SOP Common Module	34
14	TID 1500. Mapping of Measurement Report	35
15	TID 1501. Mapping of Measurement Group	37
16	TID 1502. Mapping of Time Point Context	40
17	TID 1410. Mapping of Planar ROI Measurements	41
18	TID 1411. Mapping of Volumetric ROI Measurements	44
19	TID 1419. Mapping of ROI Measurements	48
20	TID 1420. Mapping of Measurements Derived From Multiple ROI Measurements	52
21	TID 300. Mapping of Measurement	54
22	TID 320. Mapping of Image or Spatial Coordinates	58
23	TID 4019. Mapping of Algorithm Identification	59
24	TID 4108. Mapping of Tracking Identifier	60
25	TID 1204. Mapping of Language of Content Item and Descendants	60
26	TID 1001. Mapping of Observation Context	61
27	TID 1002. Mapping of Observer Context	61
28	TID 1003. Mapping of Person Observer Identifying Attributes	62
29	TID 1600. Mapping of Image Library	63
30	TID 1601. Mapping of Image Library Entry	63
31	TID 1602. Mapping of Image Library Entry Descriptors	64
32	A.7.2-1. Transformed SR document encoding at the Attribute level	71
33	A.8-1. ISO 21090 Data Types used in AIM V4	89
34	A.8-2. Mapping between DICOM Basic Code Attributes and AIM ISO 21090 Code Data Types (CD)	90
35	A.8-3. Mapping between DICOM Person Name (PN) and ISO 21090 Data Type Person Name (PN)	90
36	A.8-4. Mapping between DICOM Numeric Measurement Value Types and ISO 21090 Data Types	91
37	A.8-5. Mapping between DICOM Numeric Value Qualifier Code Sequence and AIM ST	92
38	A.8-6. DICOM Image references to AIM Path	93
39	A.8-7. DICOM Segmentation references to AIM Path	93

Scope and Field of Application

This Supplement defines patterns for transformation of measurement and annotation information for use-cases related to the reporting of quantitative imaging results.

The Annotation and Image Markup (AIM) project defines a UML model and an XML schema for describing the observations that humans or machines make about specific semantic types of information in images: anatomic entities, imaging observations and their characteristics, quantitative imaging features of targets of interest, and other information about targets in images. AIM enables recording qualitative and quantitative features of images.

The AIM model captures annotation descriptions, markup (graphical drawing using graphical types consistent with those used in DICOM), computational results of image features and ancillary information related to images into a single common information source. This information is captured using user-defined lexicons and/or well-defined medical lexicons such as RadLex, UMLS, SNOMED CT®, CPT, ICD-9/10, etc. Where it is appropriate a question, also captured as coded term, can be associated with answers.

Image annotations in AIM have been used for cancer lesion measurements and ROIs for capturing quantitative imaging features, and it is desirable to harmonize this effort with similar capabilities that exist in DICOM, to allow AIM and DICOM systems to interoperate for these use cases.

DICOM PS3.16 defines various templates for different applications. The TID 1500 Measurement Report template describes a generic pattern that is similar to AIM and has been used for the same use cases.

This supplement defines a mapping between compatible components of the AIM model and the DICOM SR TID 1500 Measurement Report applicable to quantitative and categorical description of regions of interest in images. It reuses the existing DICOM SR TID 1500 and the existing family of IODs sufficient to encode it (e.g., the Enhanced SR IOD and Storage SOP Class). It is not the goal to define a unique AIM template or IOD or SOP class, but rather to be interoperable with TID 1500 implementations and generic DICOM storage systems.

This supplement adds a new part for this purpose.

DICOM PS3.1 Changes

Amend DICOM PS3.1 as follows (changes to existing text are bold and underlined for additions and ~~struckthrough~~ for removals):

6.1 Document Structure

DICOM consists of the following parts:

- ...
- **PS3.21: Transformations between DICOM and other Representations**

These parts of the Standard are related but independent documents. A brief description of each Part is provided in this section.

6.21 **PS3.21: Transformations between DICOM and other Representations**

PS3.21 "Transformations between DICOM and other Representations" of the DICOM Standard specifies the transformations between DICOM and other representations of the same information. Within its scope are transformations to and from the NCI Annotation and Image Markup format.

DRAFT

DICOM PS3.16 Changes

Amend DICOM PS3.16 as follows (changes to existing text are bold and underlined for additions and ~~struckthrough~~ for removals):

TID 300 Measurement

This Template provides a general structure for a numeric measurement, together with evaluations of its normality and/or significance, and the inference source(s) for its value. This structure is instantiated by inclusion of this Template with specific contextual parameters from a parent Template.

Table TID 300. Measurement

	NL	Rel with Parent	VT	Concept Name	VM	Req Type	Condition	Value Set Constraint
1			NUM	\$Measurement	1	M		UNITS = \$Units
2	>	HAS CONCEPT MOD	CODE	\$ModType	1-n	U		\$ModValue
3	>	HAS CONCEPT MOD	CODE	EV (G-C036, SRT, "Measurement Method")	1	U		\$Method
4	>	HAS CONCEPT MOD	CODE	EV (121401, DCM, "Derivation")	1	U		\$Derivation
...
18	>	INFERRED FROM	COMPOSITE	EV (126100, DCM, "Real World Value Map used for measurement")	1	U		SOP Class UID shall be Real World Value Mapping Storage ("1.2.840.10008.5.1.4.1.1.67")
19	≥	<u>HAS CONCEPT MOD</u>	<u>INCLUDE</u>	<u>DTID 4019 “GAD Algorithm Identification”</u>	1	<u>U</u>		

TID 1419 ROI Measurements

This Template encodes measurements for some metric, e.g., density, flow, or concentration.

Type: Extensible
Order: Non-Significant
Root: No

Table TID 1419. ROI Measurements

	NL	Rel with Parent	VT	Concept Name	VM	Req Type	Condition	Value Set Constraint
...
5			NUM	\$Measurement	1-n	M		UNITS = \$Units
6	>	HAS CONCEPT MOD	CODE	\$ModType	1-n	U		\$ModValue
7	>	HAS CONCEPT MOD	CODE	EV (G-C036, SRT, "Measurement Method")	1	U		\$Method
8	>	HAS CONCEPT MOD	CODE	EV (121401, DCM, "Derivation")	1	U		\$Derivation
...

	NL	Rel with Parent	VT	Concept Name	VM	Req Type	Condition	Value Set Constraint
19	>	CONTAINS	COMPOSITE	EV (126100, DCM, "Real World Value Map used for measurement")	1	U		SOP Class UID shall be Real World Value Mapping Storage ("1.2.840.10008.5.1.4.1.1.67")
20	≥	HAS CONCEPT MOD	INCLUDE	DTID 4019 "GAD Algorithm Identification"	1	U		

TID 4019 ~~GAD~~-Algorithm Identification

This Template details the algorithm unambiguously. Re-state the software identification from the General Equipment Module of the SR IOD if all algorithms are unambiguously defined by that module.

Type: Non-Extensible
Order: Significant
Root: No

Table TID 4019. ~~GAD~~-Algorithm Identification

	NL	Rel with Parent	VT	Concept Name	VM	Req Type	Condition	Value Set Constraint
1			TEXT	EV (111001, DCM, "Algorithm Name")	1	M		
2			TEXT	EV (111003, DCM, "Algorithm Version")	1	M		
3			TEXT	EV (111002, DCM, "Algorithm Parameters")	1-n	U		

TID 1003 Person Observer Identifying Attributes

This Template contains identifying (and optionally descriptive) attributes of persons that are observers.

Type: Extensible
Order: Significant
Root: No

Table TID 1003. Person Observer Identifying Attributes

	NL	Rel with Parent	VT	Concept Name	VM	Req Type	Condition	Value Set Constraint
1			PNAME	EV (121008, DCM, "Person Observer Name")	1	M		
1a			TEXT	EV (128774, DCM, "Person Observer's Login Name")	1	U		
2			TEXT	EV (121009, DCM, "Person Observer's Organization Name")	1	U		Defaults to Institution Name (0008,0080) of the General Equipment Module
3			CODE	EV (121010, DCM, "Person Observer's Role in the Organization")	1	U		BCID "Organizational Roles"
4			CODE	EV (121011, DCM, "Person Observer's Role in this Procedure")	1	U		BCID 7453 "Performing Roles"

	NL	Rel with Parent	VT	Concept Name	VM	Req Type	Condition	Value Set Constraint
5	≥	<u>HAS</u> <u>CONCEPT</u> <u>MOD</u>	<u>TEXT</u>	<u>EV (128775, DCM, "Identifier within Person Observer's Role")</u>	1	<u>U</u>		

D DICOM Controlled Terminology Definitions (Normative)

Table D-1. DICOM Controlled Terminology Definitions

Code Value	Code Meaning	Definition	Notes
<u>128774</u>	<u>Person Observer's Login Name</u>	<u>Login name (user ID) of human observer who created the observations.</u>	
<u>128775</u>	<u>Identifier within Person Observer's Role</u>	<u>An alphanumeric designator of an individual within a role.</u>	

DRAFT

DICOM PS3.21 Transformations between DICOM and other Representations

Add new DICOM PS3.21 - Transformations between DICOM and other Representations as follows:

DRAFT

PS3.21

DICOM PS3.21 2017e - Transformations between DICOM and other Representations

DICOM Standards Committee

Copyright © 2017 NEMA

DRAFT

Notice and Disclaimer

The information in this publication was considered technically sound by the consensus of persons engaged in the development and approval of the document at the time it was developed. Consensus does not necessarily mean that there is unanimous agreement among every person participating in the development of this document.

NEMA standards and guideline publications, of which the document contained herein is one, are developed through a voluntary consensus standards development process. This process brings together volunteers and/or seeks out the views of persons who have an interest in the topic covered by this publication. While NEMA administers the process and establishes rules to promote fairness in the development of consensus, it does not write the document and it does not independently test, evaluate, or verify the accuracy or completeness of any information or the soundness of any judgments contained in its standards and guideline publications.

NEMA disclaims liability for any personal injury, property, or other damages of any nature whatsoever, whether special, indirect, consequential, or compensatory, directly or indirectly resulting from the publication, use of, application, or reliance on this document. NEMA disclaims and makes no guaranty or warranty, expressed or implied, as to the accuracy or completeness of any information published herein, and disclaims and makes no warranty that the information in this document will fulfill any of your particular purposes or needs. NEMA does not undertake to guarantee the performance of any individual manufacturer or seller's products or services by virtue of this standard or guide.

In publishing and making this document available, NEMA is not undertaking to render professional or other services for or on behalf of any person or entity, nor is NEMA undertaking to perform any duty owed by any person or entity to someone else. Anyone using this document should rely on his or her own independent judgment or, as appropriate, seek the advice of a competent professional in determining the exercise of reasonable care in any given circumstances. Information and other standards on the topic covered by this publication may be available from other sources, which the user may wish to consult for additional views or information not covered by this publication.

NEMA has no power, nor does it undertake to police or enforce compliance with the contents of this document. NEMA does not certify, test, or inspect products, designs, or installations for safety or health purposes. Any certification or other statement of compliance with any health or safety-related information in this document shall not be attributable to NEMA and is solely the responsibility of the certifier or maker of the statement.

DRAFT

Foreword

This DICOM Standard was developed according to the procedures of the DICOM Standards Committee.

The DICOM Standard is structured as a multi-part document using the guidelines established in [ISO/IEC Directives, Part 2].

DRAFT

1 Scope and Field of Application

This part of the DICOM Standard specifies the transformations between DICOM and other representations of the same information.

Currently, this Part addresses:

- compatible components of the NCI Annotation and Image Markup (AIM) to and from DICOM SR Measurement Templates, applicable to quantitative and categorical description of regions of interest in images

Transformation of diagnostic imaging reports between DICOM SR and HL7 CDA representations is addressed in PS3.20.

DRAFT

2 Normative and Informative References

The following standards contain provisions that, through reference in this text, constitute provisions of this Standard. At the time of publication, the editions indicated were valid. All standards are subject to revision, and parties to agreements based on this Standard are encouraged to investigate the possibilities of applying the most recent editions of the standards indicated below.

[ISO/IEC Directives, Part 2] ISO/IEC. 2016/05. 7.0. *Rules for the structure and drafting of International Standards*. http://www.iec.ch/members_experts/refdocs/iec/isoiecdir-2%7Bed7.0%7Den.pdf .

[IEEE 754] IEEE. 1985. *32-bit and 64-bit Floating Point Number Representations*.

[ISO 21090] ISO. 2011. *Health informatics -- Harmonized data types for information interchange*. http://www.iso.org/iso/iso_catalogue/catalogue_tc/catalogue_detail.htm?csnumber=35646 .

[V3 DT R1] HL7. 2004. *HL7 Version 3 Standard: XML Implementation Technology Specification - Wire Format Compatible Release 1 Data Types, Release 1*. http://www.hl7.org/implement/standards/product_brief.cfm?product_id=357 .

[XML] W3C. 2006/09/29. *Extensible Markup Language (XML) 1.1*. <http://www.w3.org/TR/2006/REC-xml11-20060816/> .

[XSD Datatypes] W3C. 2004/10/28. *XML Schema Part 2: Datatypes*. <http://www.w3.org/TR/xmlschema-2/> .

[AIM v3 v4 changes] NCI. 2014/04/10. *Changes from AIM 3.0, Revision 11 to AIM Foundation - Summary of Changes Between AIM 3.0 and 4.0 Models*. <https://wiki.nci.nih.gov/display/AIM/Changes+from+AIM+3.0%2C+Revision+11+to+AIM+Foundation#ChangesfromAIM3.0,Revision11toAIMFoundation-ISO21090DataTypes> .

[AIM Model v4 rv48] NCI. 2013/03. *Annotation and Image Markup model version 4*. <https://wiki.nci.nih.gov/display/AIM/Annotation+and+Image+Markup+-+AIM#AnnotationandImageMarkup-AIM-AIMModel> .

[Extending AIM] NCI. 2014/12/03. *Extending the AIM Model*. <https://wiki.nci.nih.gov/display/AIM/Extending+the+AIM+Model> .

[caBIG™ AIM] *J Digit Imaging*. Channin, David S, Mongkolwat, Pattanasak, Kleper, Vladimir, Sepukar, Kastubh, and Rubin, Daniel L. 2010/04. 23. 2. 217–225. “The caBIG™ Annotation and Image Markup Project”. 10.1007/s10278-009-9193-9. <http://www.ncbi.nlm.nih.gov/pmc/articles/PMC2837161/> .

[AIM Template Builder] *Radiographics*. Mongkolwat, Pattanasak, Channin, David S, Kleper, Vladimir, and Rubin, Daniel. 2012/07. 32. 4. 1223–1232. “An Open-Source and Open-Access Cancer Biomedical Informatics Grid Annotation and Image Markup Template Builder”. 10.1148/rg.324115080. <http://www.ncbi.nlm.nih.gov/pmc/articles/PMC3393884/> .

[AIM Foundation Model] *J Digit Imaging*. Mongkolwat, Pattanasak, Kleper, Vladimir, Talbot, Skip, and Rubin, Daniel. 2014/12. 27. 6. 692–701. “The National Cancer Informatics Program (NCIP) Annotation and Image Markup (AIM) Foundation Model”. 10.1007/s10278-014-9710-3. <http://www.ncbi.nlm.nih.gov/pmc/articles/PMC4391072/> .

3 Definitions

For the purposes of this Standard the following definitions apply.

3.1 Codes and Controlled Terminology Definitions:

The following definitions are commonly used in this Part of the DICOM Standard:

Coding Schemes	Dictionaries (lexicons) of concepts (terms) with assigned codes and well defined meanings. See Section 3.1 "Codes and Controlled Terminology Definitions" in PS3.16.
Content Item	A node in the Content Tree of a DICOM SR document, consisting of either a container with a coded Concept Name, or a name-value pair with a coded Concept Name and a Concept Value.
Content Tree	The tree of Content Items of a DICOM SR document.
Context Group	A set of coded concepts defined by a Mapping Resource forming a set appropriate to use in a particular context. See Section 3.1 "Codes and Controlled Terminology Definitions" in PS3.16.
Context ID (CID)	Identifier of a Context Group. See Section 3.1 "Codes and Controlled Terminology Definitions" in PS3.16.
Template	A pattern that describes the Content Items, Value Types, Relationship Types and Value Sets that may be used in part of a Structured Report Content Tree, or in other Content Item constructs, such as Acquisition Context or Protocol Context. Analogous to a Module of an Information Object Definition. See Section 3.1 "Codes and Controlled Terminology Definitions" in PS3.16.
Template ID (TID)	Identifier of a Template. See Section 3.1 "Codes and Controlled Terminology Definitions" in PS3.16.

4 Symbols and Abbreviations

The following symbols and abbreviations are used in this Part of the Standard.

AIM	Annotation and Image Markup
DICOM	Digital Imaging and Communications in Medicine
IOD	Information Object Definition
ISO	International Standards Organization
NCI	National Cancer Institute
NEMA	National Electrical Manufacturers Association
OID	Object Identifier (ISO 8824)
SR	Structured Reporting
UCUM	Unified Code for Units of Measure
UID	Unique Identifier
XML	Extensible Markup Language
XSLT	Extensible Stylesheet Language Transformations

DRAFT

5 Conventions

Terms listed in Section 3 Definitions are capitalized throughout the document.

DRAFT

A Transformation Between AIM and DICOM SR

A.1 Scope and Field of Application

NCI AIM objects that are constrained to specific use cases can be transformed to DICOM SR documents that are based on TID 1500.

NCI AIM specifies a generic model for encoding structured information about medical images. The AIM model and its XML encoding are version specific. The version transformed in this document is Version 4 [Extending AIM]. Though AIM instances can be generated according to application-specific templates [ref. AIM template builder], such templates are too use-case specific to be detailed in the transformation described in this Part. Rather, common patterns of use implemented by well known implementations (ref. CC, ref ePAD) have been abstracted and are mapped as described in this document.

DICOM SR specifies a generic model for encoding structured information about DICOM instances. DICOM TID 1500 Measurement Report specifies a basic DICOM SR report template for quantitative measurements and categorical statements for single identifiable patient subjects including regions of interest defined by spatial coordinates or segmentations.

A.2 Use Cases

The basic use case for the transformation from AIM to DICOM SR is exchange of quantitative and categorical information about DICOM images and regions of interest in DICOM images.

AIM and DICOM SR instances both contain references to DICOM images, and both make use of references to other types of DICOM instances such as segmentations. The flow of information between systems that might make use of a conversion between AIM and DICOM SR instances is considered in Figure A.2-1.

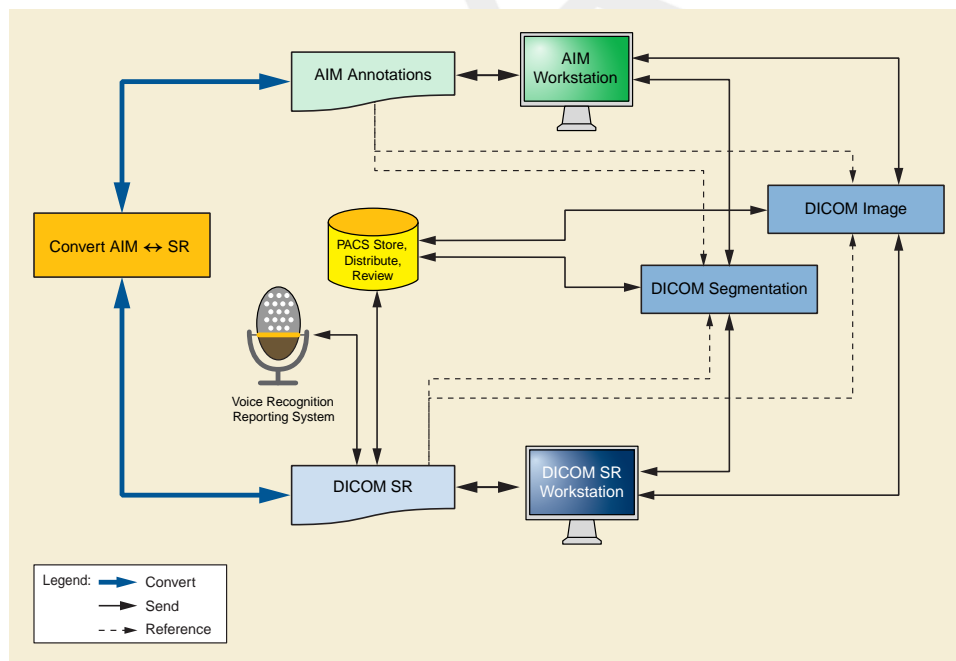

Figure A.2-1. Annotation Creation and Transformation

Various different transformation scenarios should be considered:

- a. Transformation of a complete AIM instance to a complete DICOM SR Measurement Report. The receiver optionally selects relevant parts of the transformed document for further processing or static or interactive visualization by the user.

- 1 b. Transformation of a subset of a AIM instance to a DICOM SR Measurement Report. This subset comprises the relevant inform-
2 ation for a specific use-case.
- 3 c. Transformation of multiple related AIM instances to a single DICOM SR Measurement Report. The selected related AIM instances
4 comprise the relevant information for a specific use-case.

5 This part of the Standard does not mandate any particular transformation scenario. Transformations of various compatible components
6 of AIM and DICOM SR TID 1500 are described, allowing each of these scenarios to be implemented as appropriate. This part of the
7 Standard enables a deterministic transformation of the first scenario (complete mapping of an AIM instance to DICOM).

8 The primary use-case for the transformation is that of:

- 9 • taking an existing AIM instance containing one or more annotations, converting it into DICOM SR, storing it in a DICOM storage
10 system, possibly displaying it with a DICOM SR aware application, transforming it back into an AIM instance after retrieval from
11 the DICOM storage system, and reusing it in an AIM-aware application

12 An important secondary use-case is transformation of annotation information in different formats into a single format for data aggreg-
13 ation (e.g., "analytics", "data mining", "big data", "machine learning", and "deep learning"). The conversion described here is intended
14 to allow preservation of semantics sufficient for such purposes, regardless of the source format.

15 It should be understood that DICOM SR created by transforming an AIM object will not necessarily be identical in structure and content
16 to a DICOM SR that might have been created de novo by a similar application. For instance, there are various encoding choices that
17 an application implementer may make, especially with respect to the degree of post-coordination of ROI and measurement descriptions,
18 which might result in different structures. It may not be possible to transform a DICOM SR TID 1500 instance into AIM and retain all
19 of its content. Post-coordinated concepts, such as measurement and derivation methods, may be preserved by using multiple Calcula-
20 tionEntity/typeCode entries or by pre-coordinating into a single concept during the transformation.

21 Multiple regions of interest, or multiple measurements and categorical statements about a single region of interest, or about the same
22 real world entity (e.g., lesion) identified with different regions of interest (e.g., at different time points or with different modalities), may
23 be encoded in single or multiple AIM or DICOM SR instances. Whether or not a source AIM or DICOM SR implementation encodes
24 more than one region of interest (and their accompanying measurements and categorical statements) in a single instance or in sep-
25 arate instances, and whether the conversion from one form to the other "bundles" multiple instances into a single instance, or "unbundles"
26 a single instance into multiple instances, is not prescribed. The AIM 4.0 model allows for the encoding of multiple marked up regions
27 and multiple measurements in a single annotation instance, but does not provide a mechanism for identifying which markup is asso-
28 ciated with which measurement; it is therefore necessary to assume that all markup applies to all measurements and vice versa.

- 29 1. For example, for RECIST measurements that involve the long and short axis of a lesion, though it is currently possible to encode
30 in AIM (and map to TID 1500) the measurements as derived from a planar volumetric ROI, and recognize them by their concept
31 name code, it is not also possible to encode the endpoints of the measured axes of the pair of linear measurements. Nor is a
32 reverse mapping of such information encoded in TID 1500 into AIM possible. Some current AIM implementations use private
33 extensions to address this use case, but mapping these is beyond the scope of the Standard.
- 34 2. It is expected that a future revision of the AIM 4.0 model will allow for explicit linkage of markup and measurements, probably
35 using statements, e.g., CalculationEntityReferencesMarkupEntityStatement and CalculationEntityReferencesSegmentationEntityS-
36 tatement, at which time the appropriate mappings will be added.

37 **A.3 Structure of DICOM SR Documents**

38 DICOM SR documents can be thought of as consisting of a document header and a document body. The header metadata attribute
39 values are grouped into modules such as "Patient", "General Study" in PS3.3.

40 The SR Document Content Module contains the attributes for the root Content Item, which includes the coded report title. The Content
41 Tree (structured content) of the document body is contained in the nested Content Sequence Items of that module. "Container"
42 Content Items are part of the Content Sequence. They are structural elements of the SR document body structure. Content items are
43 DICOM SR document nodes within the Content Tree that are connected through "by-value" relationships (for Enhanced SR IODs).
44 The transformations defined in this Part do not support the use of "by-reference" relationships between Content Items.

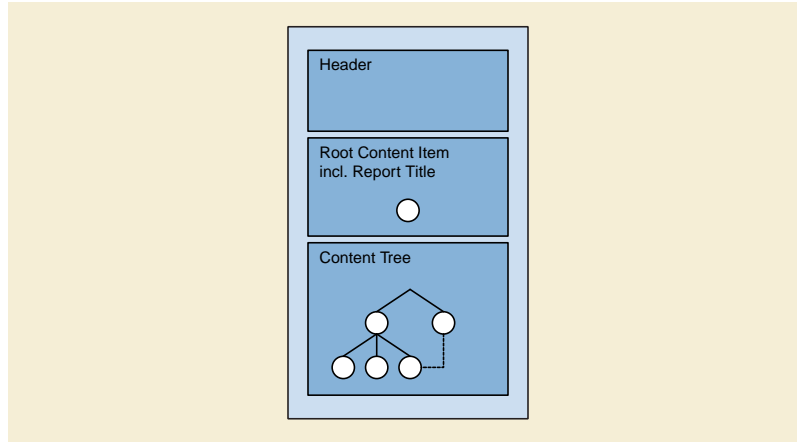

Figure A.3-1. SR Document Structure

A.3.1 Header

The Modules used in a DICOM SR are defined by the Information Object Definition (IOD). A particular DICOM SR template may be encoded using a variety of DICOM SR IODs, depending on the features supported by the template and used by a particular instance. Each SR IOD constrains the Value Types and Relationship Types that are permitted. The Enhanced SR IOD is sufficient to encode TID 1500 instances unless 3D patient-relative coordinates (rather than 2D image-relative coordinates or segmentations) are used to define regions of interest on images, in which case use of the Comprehensive 3D SR IOD or Extensible SR IOD would be required.

Table A.3.1-1 summarizes the modules common to the SR IODs that can encode the TID 1500 as specified in PS3.3.

Table A.3.1-1. Transformation of DICOM SR IOD Modules

IE	Module	Reference	Usage	Transformation
Patient	Patient	C.7.1.1	M	Section A.6.1.1.1
	Clinical Trial Subject	C.7.1.3	U	Section A.6.1.1.2
Study	General Study	C.7.2.1	M	Section A.6.1.1.3
	Patient Study	C.7.2.2	U	Section A.6.1.1.4
	Clinical Trial Study	C.7.2.3	U	Section A.6.1.1.5
Series	SR Document Series	C.17.1	M	Section A.6.1.1.6
	Clinical Trial Series	C.7.3.2	U	Section A.6.1.1.7
Equipment	General Equipment	C.7.5.1	M	Section A.6.1.1.8
Document	SR Document General	C.17.2	M	Section A.6.1.1.9
	SR Document Content	C.17.3	M	Section A.6.1.1.10
	SOP Common	C.12.1	M	Section A.6.1.1.11

Patient Module

The Patient Module specifies the Attributes of the Patient that describe and identify the Patient who is the subject of a Study. This Module contains Attributes of the patient that are needed for interpretation of the Image and are common for all studies performed on the patient.

Clinical Trial Subject Module

The Clinical Trial Subject Module contains attributes that identify a Patient as a clinical trial Subject.

General Study Module

1 The General Study Module specifies the Attributes that describe and identify the Study performed upon the Patient.

2 **Patient Study Module**

3 The Patient Study Module defines the attributes that provide information about the Patient at the time the Study was performed.

4 **Clinical Trial Study Module**

5 The Clinical Trial Study Module contains attributes that identify a Study in the context of a clinical trial.

6 **SR Document Series Module**

7 The SR Document Series Module defines the Attributes of the SR Document Series. A Series of SR Documents may contain any
8 number of SR Documents.

9 **Clinical Trial Series Module**

10 The Clinical Trial Series Module contains attributes that identify a Series in the context of a clinical trial.

11 **General Equipment Module**

12 The General Equipment Module specifies the Attributes that identify and describe the piece of equipment that produced a Series of
13 Composite Instances.

14 **SR Document General Module**

15 The SR Document General Module defines the general Attributes of an SR Document Instance. These Attributes identify the SR
16 Document and provide context for the entire document.

17 **SOP Common Module**

18 The SOP Common Module defines the Attributes that are required for proper functioning and identification of the associated SOP
19 Instances.

20 **SR Document Content Module**

21 The Attributes in this Module convey the content of an SR Document. It specifies the root Content Item and the Content Tree (refer
22 to Figure A.3-1).

23 **A.3.2 Document Body**

24 The document body is the information that is stored in the DICOM SR Content Tree. The Content Tree is encoded in the SR Document
25 Content Module.

26 **A.3.2.1 DICOM SR "Measurement Report" Template Structure**

27 TID 1500 is the top-level template of the DICOM SR Measurement Report (PS3.16). It includes sub-templates as shown in Fig-
28 ure A.3.2.1-1.

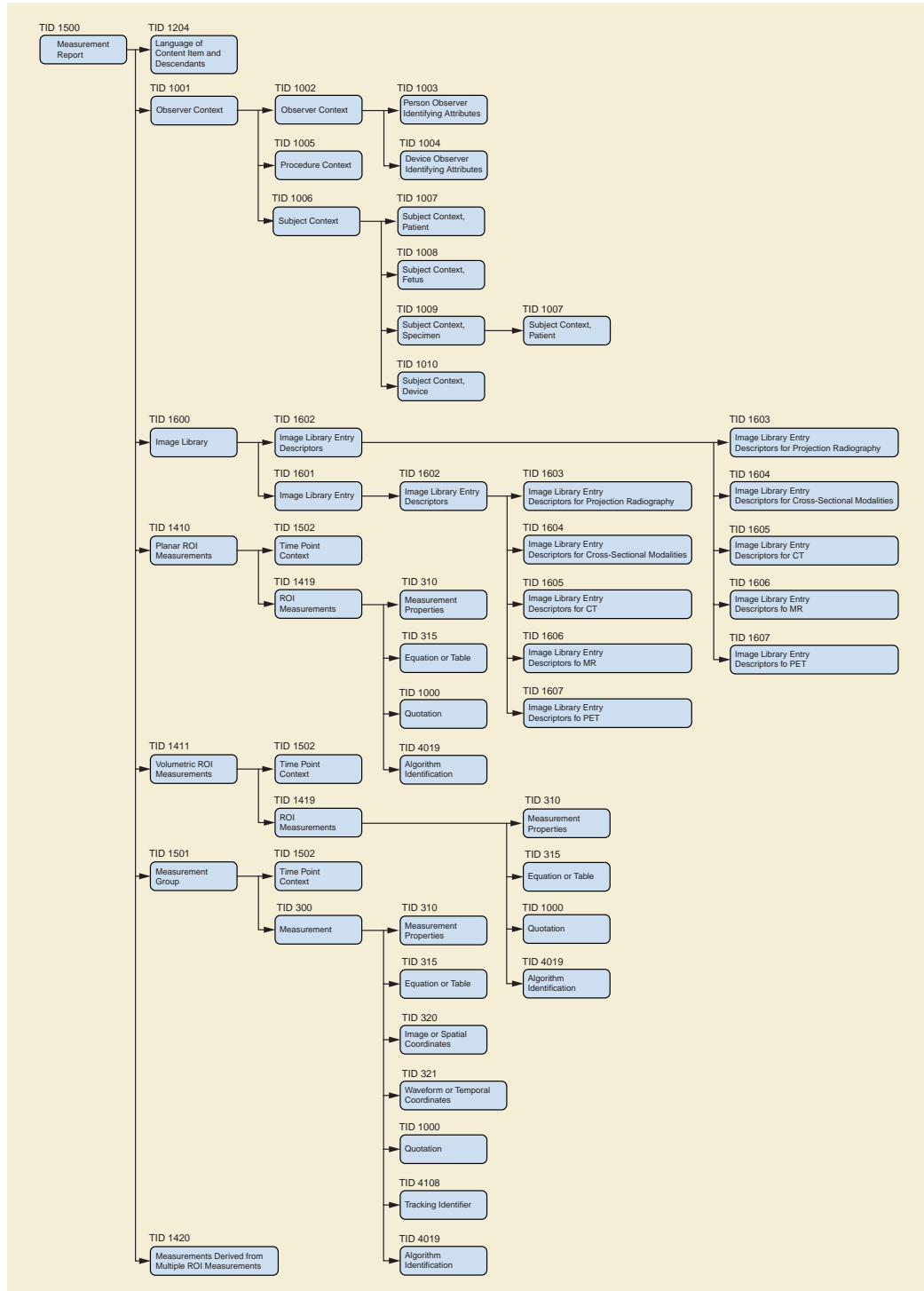

Figure A.3.2.1-1. Template Structure Summarized from PS 3.16

Note

1. The use of TID 1001 Observation Context within TID 1000 Quotation is not shown because it is not relevant to the mapping use cases.

2. The use of TID 311 Measurement Statistical Properties and TID 312 Normal Range Properties within TID 310 Measurement Properties is not shown because it is not relevant to the mapping use cases.
3. The use of TID 1410 Planar ROI Measurements, TID 1411 Volumetric ROI Measurements, and TID 310 Measurement Properties within TID 1420 is not shown because it is not relevant to the mapping use cases.

A.3.2.2 Mapping Considerations

The goal of this document is to specify a mapping between constrained AIM v4 instances and TID 1500 Measurement Report DICOM SR documents. The following limitations apply to AIM instances that are mapped to DICOM SR Measurement Reports:

- Subject Context: The DICOM SR TID 1500 Measurement Report is restricted to cover exactly one patient subject; the mapping of subject context of fetuses, specimens or devices as subjects is out of scope. Small or large animal identifiers and descriptors (beyond reuse of the normal patient identifiers) are not specifically addressed since no such identifiers are present in the AIM model (e.g., multiple animals imaged as one, and strain descriptions are out of scope).
- The mapping of DICOM SR clinical trial header data (Clinical Trial Subject Module, Clinical Trial Study Module, Clinical Trial Series Module) is not described since no such identifiers are present in the AIM model.
- The transformation of de-identified objects is not specifically addressed in this mapping, since AIM does not address encoding of the history of de-identification explicitly. I.e., identifiers will be converted unchanged and whether they have been de-identified will not be explicitly signaled.
- A subset of spatial coordinate types are mapped, to the extent that both AIM and DICOM SR support the same graphic concepts.

A.3.2.3 DICOM Composite Object References

The hierarchical attributes describing DICOM composite object references are used whenever DICOM composite objects are referenced in the Content Tree and are also described in the Image Library templates and the Current Requested Procedure Evidence Sequence (0040,A375) or Pertinent Other Evidence Sequence (0040,A385). Information on relevant DICOM objects referenced within the AIM instance are included in the AIM DicomImageReferenceEntity class.

A.4 Structure of AIM Version 4 Instances

AIM instances are encoded in XML according to a schema generated from the AIM Model [AIM Model v4 rv48], which is defined in UML. Figure A.4-1 is a simplified view rather than the entire model, showing only those UML classes and attributes relevant to the transformations described in this part.

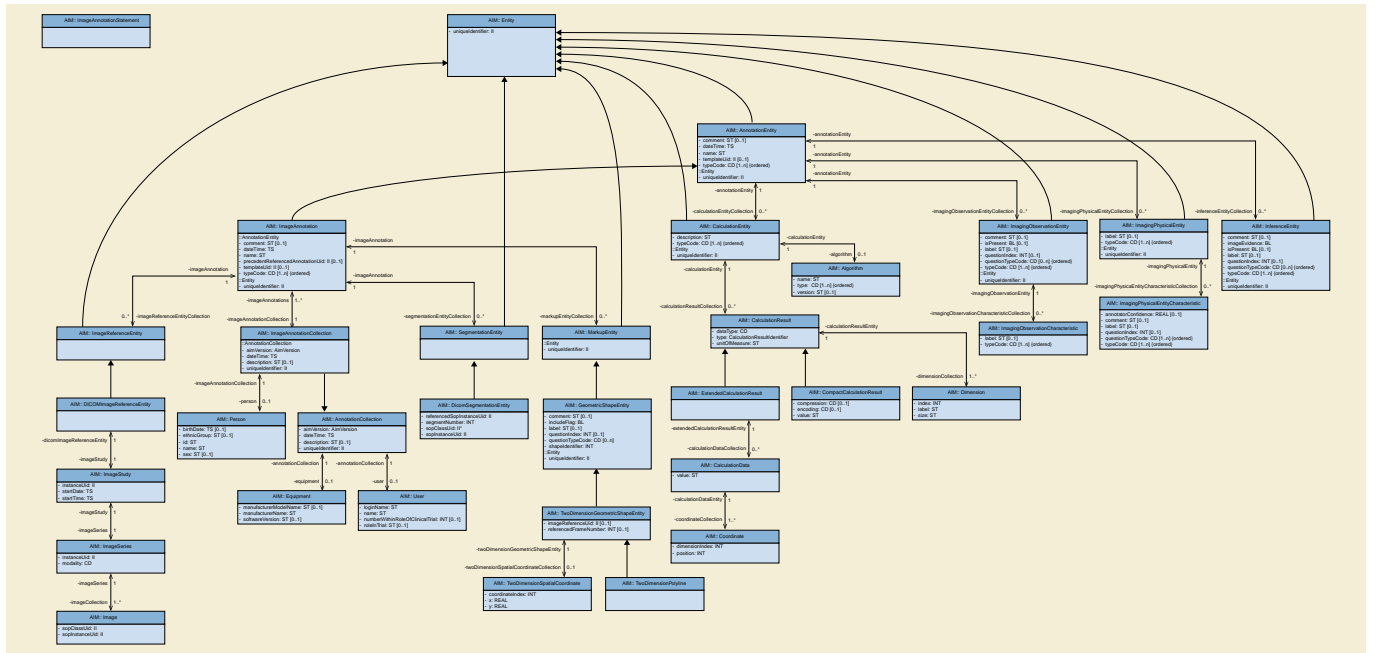

Figure A.4-1. AIM v4 Instance Structure

A.5 AIM v4 Structure

Version 4 of AIM makes use of [ISO 21090] data types. See Section A.8 “Overview of Data Types”.

A.6 AIM v4 to DICOM TID 1500 Mapping

The transformation is described in one direction, by enumerating the structures in the target (DICOM SR TID 1500) and describing where in the source (AIM v4) the corresponding information may be obtained. The information is tabulated in a manner that can be implemented as an automated "pull" conversion of an AIM instance into a DICOM SR instance, such as might be described using a transformation language such as XSLT. The transformation is intended to be reversible, i.e., by inverting the target and the source, even though round-trip full fidelity will not be achieved in some cases. Gaps that exist in the information required in the target to create a compliant object, which need to be filled by information from an out of band source or generated de novo, are highlighted. Information in the source that is not "pulled" into the DICOM encoding will be lost; these omissions are deemed to be harmless from the perspective of the relevant use cases.

The tabular representations make use of the following conventions in order to simplify the automatic extraction and use as a formal syntax to drive implementations:

- DICOM attributes are represented by keywords defined in PS3.6, rather than specifying the data element group and element tags.
- DICOM attributes that are nested within sequences are shown as a path from the top level data set separated by a ">" symbol.
- AIM classes, attributes and associations are represented using their XPath representation as encoded in XML instances.
- DICOM Code Sequence attributes are mapped from AIM CD data type attributes without fully enumerating the corresponding subordinate DICOM attributes and XML elements and attributes.
- Other DICOM Sequences are listed, without a mapping on the same row, but with the following rows describing the individual DICOM Attributes nested within that Sequence.
- All source and target paths are fully qualified relative to the root of the instance in order to make the transformation reversible. I.e., it would be possible to describe some transformations using the descendant-or-self axis XSLT operator ("//") if the source were unambiguous but that would not specify the location reversibly as a target. Accordingly, some of the explicit paths are quite long.

- The requirement type for DICOM Attributes is as defined in PS3.3 for Attributes in Modules and Macros, except that if the containing Module in the IOD is not required, e.g., is U rather than M, then a mandatory (Type 1 or 2) Attribute in a user optional (type U) Module is shown as optional (Type 3).
- The data type and cardinality are specified for both the source and the target, to highlight potential mismatches that may occur during transformation. For nested elements and attributes, the multiplicity is expressed as the combination of the multiplicity along the entire path. For example, the aim:name attribute has a multiplicity of 1:1 in an aim:Person class but is associated with the aim:ImageAnnotationClass with a multiplicity of 1 -> 0:1, so the multiplicity is indicated as 0:1, not 1:1, since that is the net effect. The DICOM multiplicity is either the VM for the data element or the number of Sequence Items if the data element is a Sequence.

The XML representation of the AIM UML collapses some associations and classes such that they are encoded as a single element, and this is reflected in the mapping paths. For example, the aim:Person class has an aim:person association from the aim:ImageAnnotationCollection class, so the path to the aim:name attribute is expressed as /ImageAnnotationCollection/person/name, as it appears in the XML instance.
- Data type transformations are assumed and are not described further unless there is a specific requirement. For example, conversion from DICOM DA, TM and DT VR Attributes to AIM TS Data Type values is implicit, including extraction/population of the appropriate sub-fields (i.e., only the date portion of a TS is used when creating a DICOM DA value).
- If value sets are defined for both AIM and DICOM, then value mappings are described. In some cases, explicit value sets are not defined. For example, aim:Person/sex has no explicitly defined value set but maps to DICOM PatientSex, which does; so if AIM implementations use the DICOM values, and the values are copied, then the transformation without value mapping will be successful, but not otherwise.
- When a mapping is defined but no transformation source is available but a value is required, a Generated Value is indicated, which may be a fixed constant (e.g., a Modality value of "SR"), an indication that an empty (zero length) value or sequence is required, or an indication that a new value of the appropriate VR needs to be generated (e.g., a new UID for a UI VR, a new integer for an IS VR, etc.). The need to generate new values will not produce a deterministic result without a memory of previous conversions.
- Optional content in the target that has no defined source is not described (e.g., DICOM SeriesDescription in the General Series Module has no correlate in AIM, though it would be useful to populate with a generated value).
- When the same DICOM Attribute is described in two different Modules, the more specialized (restrictive) use is described in the mapping tables. E.g., InstanceNumber is Type 3 in the SOP Common Module but Type 1 in the SR Document General Module, so it is only described in the latter.
- Capitalization and punctuation of DICOM keywords and AIM class, attribute and association names are significant.

A.6.1 Mapping of Constrained AIM v4

A.6.1.1 Header

General Remarks on the mapping of DICOM header module attributes:

SR Document General Module

- Mapped AIM objects are considered "unverified", so there is no requirement to record the identity of the Verifying Observer; if the "recording" observer identity is required (aim:user class attributes) it may be mapped to Author Observer Sequence (0040,A078) in the SR Document General Module (and entries in Observation Context in the Content Tree are not needed).
- Attributes of the Predecessor Documents Sequence (0040,A360) and Identical Documents Sequence (0040,A525) are not described in this transformation since they are relevant only in the context of a managed DICOM SR document environment and have no correlate in AIM.
- Attributes of the Current Requested Procedure Evidence Sequence (0040,A375) and Pertinent Other Evidence Sequence (0040,A385) are described in the transformation and provide the information described in the Hierarchical SOP Instance Reference Macro used to match composite instance references with their Study and Series context; the AIM DicomImageReferenceEntity class performs a similar function.
- Attributes of the Equivalent Document Sequence (0040,A090) are not described in the transformation since they are relevant only in the context of the original DICOM SR document.

The name space of the AIM elements is elided, and is implied to be "gme://caCORE.caCORE/4.4/edu.northwestern.radiology.AIM".

SOP Common Module

- Timezone Offset From UTC (0008,0201) shall be considered for attributes of the DICOM SR document that are based on the DA or TM data type (PS3.5). AIM date and time attributes may or may not contain explicit timezone information that may be extracted to populate Timezone Offset From UTC (0008,0201).
- The Specific Character Set (0008,0005) is required (Type 1C), if the Basic Graphic Set is expanded or replaced. This is the basis for mapping DICOM character sets to AIM XML Unicode (<?xml version="1.0" encoding="UTF-8"?>).

Note

Ambiguities exist for mapping individual characters to Unicode (e.g., for Japanese characters). Resolution of those issues is beyond the scope of this document. Please refer to Section A.8 for further details on data types and character sets.

A.6.1.1.1 Mapping of DICOM Patient Module

Table A.6.1.1.1-1. Mapping of DICOM Patient Module

DICOM Attribute	DICOM VR	DICOM VM	DICOM Usage Type	Generated Value	AIM Element or Attribute	AIM Data Type	AIM Multiplicity	Comment
PatientName	PN	1	2		ImageAnnotationCollection/person/name/@value	ST	0..1	
PatientID	LO	1	2		ImageAnnotationCollection/person/id/@value	ST	0..1	
PatientBirthDate	DA	1	2		ImageAnnotationCollection/person/birthDate/@value	TS	0..1	
PatientSex	CS	1	2		ImageAnnotationCollection/person/sex/@value	ST	0..1	
EthnicGroup	SH	1	3		ImageAnnotationCollection/person/ethnicGroup/@value	ST	0..1	

Note

If the annotation concerns a small animal that has been imaged as part of a group of animals in the same image, then the PatientID and other Attributes of this Module will be those of that individual animal, not the group. Currently there is no AIM mechanism to identify the group of animals imaged at the same time that corresponds to the DICOM SourcePatientGroupIdentificationSequence.

A.6.1.1.2 Mapping of DICOM Clinical Trial Subject Module

No mapping of the DICOM Clinical Trial Subject Module is described since no corresponding content is present in the AIM model.

A.6.1.1.3 Mapping of DICOM General Study Module

The AIM 4.0 model does not provide Study information per se (i.e., conceptually an AIM instance may exist independent of a Study, but DICOM requires that SR instances be part of a Study). Accordingly, during transformation from AIM to SR either a new Study may be generated, or the SR instance derived from the AIM object could be placed in (one of) the Study(ies) referenced by the AIM instance, assuming there are any, which produces a predictable transformation, and is described here.

If there is more than one DICOM Study referenced by the AIM object, duplicates of the converted AIM SR instance may be placed in each of the referenced studies (with different SOP Instance UIDs), in which case the IdenticalDocumentsSequence is required in the SR Document General Module; see PS3.3 C.17.2.2 Identical Documents Sequence.

Table A.6.1.1.3-1. Mapping of DICOM General Study Module

DICOM Attribute	DICOM VR	DICOM VM	DICOM Usage Type	Generated Value	AIM Element or Attribute	Data Type	Multiplicity	Comment
StudyInstanceUID	UI	1	1	New if not in source	ImageAnnotationCollection/imageAnnotations/ImageAnnotation[1]/imageReferenceEntityCollection/ImageReferenceEntity[1]/imageStudy[1]/instanceUid/@root	II	0..1	
StudyDate	UI	1	2	Empty if not in source	ImageAnnotationCollection/imageAnnotations/ImageAnnotation[1]/imageReferenceEntityCollection/ImageReferenceEntity[1]/imageStudy[1]/startDate/@value	TS	0..1	
StudyTime	UI	1	2	Empty if not in source	ImageAnnotationCollection/imageAnnotations/ImageAnnotation[1]/imageReferenceEntityCollection/ImageReferenceEntity[1]/imageStudy[1]/startTime/@value	TS	0..1	
ReferringPhysicianName	PN	1	2	Empty				Not in AIM.
StudyID	SH	1	2	Empty				Not in AIM.
AccessionNumber	SH	1	2	Empty				Not in AIM.

A.6.1.1.4 Mapping of DICOM Patient Study Module

No mapping of the DICOM Patient Study Module is described since no corresponding content is present in the AIM model.

A.6.1.1.5 Mapping of DICOM Clinical Trial Study Module

No mapping of the DICOM Clinical Trial Study Module is described since no corresponding content is present in the AIM model.

A.6.1.1.6 Mapping of DICOM SR Document Series Module

The AIM 4.0 model does not support the concept that an annotation itself is part of a series, and it cannot be made part of a referenced image series, if any, because of the rule that all instances of a series are generated on the same equipment.

Table A.6.1.1.6-1. Mapping of DICOM SR Document Series Module

DICOM Attribute	DICOM VR	DICOM VM	DICOM Usage Type	Generated Value	AIM Element or Attribute	AIM Data Type	AIM Multiplicity	Comment
Modality	CS	1	1	"SR"				

DICOM Attribute	DICOM VR	DICOM VM	DICOM Usage Type	Generated Value	AIM Element or Attribute	AIM Data Type	AIM Multiplicity	Comment
SeriesInstanceUID	UI	1	1	New				Using a generated value means that multiple round-trips may produce different values. When mapping multiple AIM instances related to the same study, if the same SeriesInstanceUID is used they will appear in the same Series.
SeriesNumber	IS	1	1	7291				A well-known value means that multiple round-trips will use the same value.
ReferencedPerformedProcedureStepSequence	SQ	1	2	Empty				

A.6.1.1.7 Mapping of DICOM Clinical Trial Series Module

No mapping of the DICOM Clinical Trial Series Module is described since no corresponding content is present in the AIM model.

A.6.1.1.8 Mapping of DICOM General Equipment Module

Table A.6.1.1.8-1. Mapping of DICOM General Equipment Module

DICOM Attribute	DICOM VR	DICOM VM	DICOM Usage Type	Generated Value	AIM Element or Attribute	AIM Data Type	AIM Multiplicity	Comment
Manufacturer	LO	1	2		ImageAnnotationCollection/equipment/manufacturer/@value	ST	0..1	
ManufacturerModelName	LO	1	3		ImageAnnotationCollection/equipment/manufacturerModelName/@value	ST	0..1	
SoftwareVersions	LO	1-n	3		ImageAnnotationCollection/equipment/softwareVersion/@value	ST	0..1	

A.6.1.1.9 Mapping of DICOM SR Document General Module

Table A.6.1.1.9-1. Mapping of DICOM SR Document General Module

DICOM Attribute	DICOM VR	DICOM VM	DICOM Usage Type	Generated Value	AIM Element or Attribute	Data Type	Multiplicity	Comment
InstanceNumber	IS	1	1	New				
CompletionFlag	CS	1	1	"COMPLETE"				

DICOM Attribute	DICOM VR	DICOM VM	DICOM Usage Type	Generated Value	AIM Element or Attribute	Data Type	Multiplicity	Comment
VerificationFlag	CS	1	1	"UNVERIFIED"				Sending a value of "VERIFIED" would trigger the need to send the Verifying Observer Sequence, which is not described in this mapping.
ContentDate	DA	1	1		ImageAnnotationCollection/dateTime/@value	TS	1..1	
ContentTime	TM	1	1		ImageAnnotationCollection/dateTime/@value	TS	1..1	
AuthorObserverSequence	SQ	1-n	3					Don't send sequence at all if observer is a device rather than a human since the device is described in the General Equipment Module.
AuthorObserverSequence > ObserverType	CS	1	1	PSN				DICOM allows PSN or DEV.
AuthorObserverSequence > PersonName	PN	1	1C		ImageAnnotationCollection/user/name/@value	ST	1..1	If PSN.
AuthorObserverSequence > PersonIdentificationCodeSequence	SQ	1	2C	Empty				If PSN. Not in AIM.
AuthorObserverSequence > InstitutionName	SQ	1	2	Empty				Not in AIM.
AuthorObserverSequence > InstitutionCodeSequence	SQ	1	2	Empty				Not in AIM.
IdenticalDocumentsSequence	SQ	1	1C	UIDs of other identical converted instances.				Required if this document is stored with different SOP Instance UIDs in one or more other Studies
CurrentRequestedProcedureEvidenceSequence	SQ	1	1					

DICOM Attribute	DICOM VR	DICOM VM	DICOM Usage Type	Generated Value	AIM Element or Attribute	Data Type	Multiplicity	Comment
CurrentRequestedProcedureEvidenceSequence>StudyInstanceUID	UI	1	1		ImageAnnotationCollection/imageAnnotations/imageReferenceEntityCollection/ImageReferenceEntity/imageStudy/instanceUid/@root	II	1..1	
CurrentRequestedProcedureEvidenceSequence>ReferencedSeriesSequence	SQ	1	1					
CurrentRequestedProcedureEvidenceSequence>ReferencedSeriesSequence>SeriesInstanceUID	UI	1	1		ImageAnnotationCollection/imageAnnotations/imageReferenceEntityCollection/ImageReferenceEntity/imageStudy/imageSeries/instanceUid/@root	II	1..1	
CurrentRequestedProcedureEvidenceSequence>ReferencedSeriesSequence>ReferencedSOPSequence	SQ	1	1					
CurrentRequestedProcedureEvidenceSequence>ReferencedSeriesSequence>ReferencedSOPSequence>ReferencedSOPClassUID	UI	1	1		ImageAnnotationCollection/imageAnnotations/imageReferenceEntityCollection/ImageReferenceEntity/imageStudy/imageSeries/imageCollection/Image/sopClassUid/@root	II	1..1	
CurrentRequestedProcedureEvidenceSequence>ReferencedSeriesSequence>ReferencedSOPSequence>ReferencedSOPInstanceUID	UI	1	1		ImageAnnotationCollection/imageAnnotations/imageReferenceEntityCollection/ImageReferenceEntity/imageStudy/imageSeries/imageCollection/Image/sopInstanceUid/@root	II	1..1	
PerformedProcedureCodeSequence	SQ	1	2	Empty				Not in AIM.

A.6.1.1.10 Mapping of DICOM SR Document Content Module

All the Attributes in the SR Document Content Module are transformed by processing the DICOM SR Content Tree, and accordingly are not described in the same tabular manner as the "header" Attributes, since the mapping depends on the DICOM SR template structure. The Attributes common to each Content Item of the Content Tree are:

- ValueType

1 • ConceptNameCodeSequence

2 • ObservationUID

3 • ContentSequence

4 Each child Content Item with a "by-value" relationship with its parent also contains:

5 • RelationshipType

6 The additional required Attributes in each Content Item depend on the ValueType:

7 • TEXT - TextValue

8 • DATETIME - DateTime

9 • DATE - Date

10 • TIME - Time

11 • PNAME - PersonName

12 • UIDREF - UID

13 • NUM - MeasuredValueSequence, MeasuredValueSequence>NumericValue, MeasuredValueSequence>MeasurementUn-
14 itsCodeSequence

15 • CODE - ConceptCodeSequence

16 • COMPOSITE - ReferencedSOPSequence, ReferencedSOPSequence>ReferencedSOPClassUID, ReferencedSOPSequence>Ref-
17 erencedSOPInstanceUID

18 • IMAGE - ReferencedSOPSequence, ReferencedSOPSequence>ReferencedSOPClassUID, ReferencedSOPSequence>Refer-
19 encedSOPInstanceUID, ReferencedSOPSequence>ReferencedFrameNumber, ReferencedSOPSequence>ReferencedSegment-
20 Number

21 • SCORD - GraphicData, GraphicType

22 • SCORD3D - ReferencedFrameOfReferenceUID, GraphicData, GraphicType

23 • CONTAINER - ContinuityOfContent, ContentTemplateSequence, ContentTemplateSequence>MappingResource, ContentTem-
24 plateSequence>TemplateIdentifier

A.6.1.1.11 Mapping of DICOM SOP Common Module

Table A.6.1.1.11-1. Mapping of DICOM SOP Common Module

DICOM Attribute	DICOM VR	DICOM VM	DICOM Usage Type	Generated Value	AIM Element or Attribute	AIM Data Type	AIM Multiplicity	Comment
SOPClassUID	UI	1	1	"1.2.840.10008.5.1.4.1.1.88.22"				The fixed value is the SOP Class UID of the Enhanced SR Storage SOP Class, which is sufficient unless SCOOD3D are used, in which case the Comprehensive 3D SR Storage SOP Class is required, which has a UID of "1.2.840.10008.5.1.4.1.1.88.34".
SOPInstanceUID	UI	1	1	Generated if more than one converted instance in separate studies.	ImageAnnotation Collection>uniqueIdentifier/@root	II	1..1	
SpecificCharacterSet	CS	1	1	"ISO_IR 192"				The fixed generated value corresponds to the normal UTF-8 specified in the XMLDecl of the XML prolog [XML] in the AIM instance. Other values may be used if they are sufficient to describe all the encoded characters in the transformed instance. E.g., it may be omitted entirely if all the characters are US-ASCII.

A.6.1.2 Content Tree

TID 1500 Mapping of Measurement Report

This section describes the mapping of PS3.16 TID 1500 "Measurement Report".

Table TID 1500. Mapping of Measurement Report

DICOM SR Path	DICOM VT	DICOM VM	DICOM Usage Type	Generated Value	AIM Element or Attribute	AIM Data Type	AIM Multiplicity	Comment
(126000, DCM, "Imaging Measurement Report")	CONTAINER	1	M					The fixed Concept Name code is an appropriate choice selected from CID 7021 "Measurement Report Document Titles" in the absence of a "document title" concept in AIM. If out of band information is available, a more appropriate code can be used.
(126000, DCM, "Imaging Measurement Report") >	INCLUDE	1	M	TID 1204 "Mapping of Language of Content Item and Descendants"				
(126000, DCM, "Imaging Measurement Report") >	INCLUDE	1	M	TID 1001 "Mapping of Observation Context"				
(126000, DCM, "Imaging Measurement Report") > (121058, DCM, "Procedure reported")	CODE	1-n	M	(P0-0099A, SRT, "Imaging procedure")				The fixed generic code value is suggested in lieu of AIM containing any information about the imaging procedure, so more specific procedure codes such as those from BCID 100 "Quantitative Diagnostic Imaging Procedures" cannot be used. If out of band information is available, a more appropriate code can be used.
(126000, DCM, "Imaging Measurement Report") >	INCLUDE	1	M	TID 1600 "Mapping of Image Library"				
(126000, DCM, "Imaging Measurement Report") > (126010, DCM, "Imaging Measurements")	CONTAINER	1	C					IFF measurements are present in the source AIM object
(126000, DCM, "Imaging Measurement Report") > (126010, DCM, "Imaging Measurements") >	INCLUDE	1-n	U	TID 1410 "Mapping of Planar ROI Measurements"				
(126000, DCM, "Imaging Measurement Report") > (126010, DCM, "Imaging Measurements") >	INCLUDE	1-n	U	TID 1411 "Mapping of Volumetric ROI Measurements"				

DICOM SR Path	DICOM VT	DICOM VM	DICOM Usage Type	Generated Value	AIM Element or Attribute	AIM Data Type	AIM Multiplicity	Comment
(126000, DCM, "Imaging Measurement Report") > (126010, DCM, "Imaging Measurements") >	INCLUDE	1-n	U	TID 1501 "Mapping of Measurement Group"				
(126000, DCM, "Imaging Measurement Report") > (126011, DCM, "Derived Imaging Measurements")	CONTAINER	1	C					Not applicable to current use cases
(126000, DCM, "Imaging Measurement Report") > (126011, DCM, "Derived Imaging Measurements") >	INCLUDE	1-n	U	TID 1420 "Mapping of Measurements Derived From Multiple ROI Measurements"				
(126000, DCM, "Imaging Measurement Report") > (C0034375, UMLS, "Qualitative Evaluations")	CONTAINER	1	C					IFF Imaging ObservationEntity elements are present in the source AIM object
(126000, DCM, "Imaging Measurement Report") > (C0034375, UMLS, "Qualitative Evaluations") > CODE	CODE	1-n	U		Image Annotation Collection/ image Annotations/ Image Annotation/ imaging Observation Entity Collection/ Imaging Observation Entity/ questionType Code,type Code	CD, CD	1, 0..1	
(126000, DCM, "Imaging Measurement Report") > (C0034375, UMLS, "Qualitative Evaluations") > TEXT	TEXT	1-n	U					Not used in AIM

TID 1501 Mapping of Measurement Group

This section describes the mapping of PS3.16 TID 1501 "Measurement Group".

Table TID 1501. Mapping of Measurement Group

DICOM SR Path	DICOM VT	DICOM VM	DICOM Usage Type	Generated Value	AIM Element or Attribute	AIM Data Type	AIM Multiplicity	Comment
(126000, DCM, "Imaging Measurement Report") > (126010, DCM, "Imaging Measurements") > (125007, DCM, "Measurement Group")	CONTAINER	1	M					
(126000, DCM, "Imaging Measurement Report") > (126010, DCM, "Imaging Measurements") > (125007, DCM, "Measurement Group") > (C67447, NCI, "Activity Session")	TEXT	1	U					Not present in AIM. Identifies the session during which the measurements were made. The NCI Thesaurus definition is "time, period, or term devoted to some activity".
(126000, DCM, "Imaging Measurement Report") > (126010, DCM, "Imaging Measurements") > (125007, DCM, "Measurement Group") > (112039, DCM, "Tracking Identifier")	TEXT	1	M		ImageAnnotationCollection/imageAnnotations/ImageAnnotation/name/@value	ST	1	
(126000, DCM, "Imaging Measurement Report") > (126010, DCM, "Imaging Measurements") > (125007, DCM, "Measurement Group") > (112040, DCM, "Tracking Unique Identifier")	UIDREF	1	M		ImageAnnotationCollection/imageAnnotations/ImageAnnotation/uniqueIdentifier/@root	II	1	Using Image Annotation/uniqueIdentifier as a proxy for Tracking Unique Identifier does not allow longitudinal identification of the same lesion because Image Annotation/uniqueIdentifier must be unique to each AIM annotation file; only Image Annotation/name can be used to recognize commonality.

DICOM SR Path	DICOM VT	DICOM VM	DICOM Usage Type	Generated Value	AIM Element or Attribute	AIM Data Type	AIM Multiplicity	Comment
(126000, DCM, "Imaging Measurement Report") > (126010, DCM, "Imaging Measurements") > (125007, DCM, "Measurement Group") > (121071, DCM, "Finding")	CODE	1	U		ImageAnnotationCollection/imageAnnotations/ImageAnnotation/typeCode	CD	1..n	Only a single aim:typeCode value can be mapped.
(126000, DCM, "Imaging Measurement Report") > (126010, DCM, "Imaging Measurements") > (125007, DCM, "Measurement Group") >	INCLUDE	1	U	TID 1502 "Mapping of Time Point Context"				Not used in AIM.
(126000, DCM, "Imaging Measurement Report") > (126010, DCM, "Imaging Measurements") > (125007, DCM, "Measurement Group") > (G-C036, SRT, "Measurement Method")	CODE	1	U					Not used in AIM at this level.
(126000, DCM, "Imaging Measurement Report") > (126010, DCM, "Imaging Measurements") > (125007, DCM, "Measurement Group") > (G-C0E3, SRT, "Finding Site")	CODE	1-n	U		ImageAnnotationCollection/imageAnnotations/ImageAnnotation/imagingPhysicalEntityCollection/ImagingPhysicalEntity[label/@value='Location' or label/@value='Lobar Location' or label/@value='Segmental Location' or label/@value='Organ Type']/typeCode	CD	1..n	If a paired structure in AIM, this entry will pre-coordinate the laterality with the site.
(126000, DCM, "Imaging Measurement Report") > (126010, DCM, "Imaging Measurements") > (125007, DCM, "Measurement Group") > (G-C0E3, SRT, "Finding Site") > (G-C171, SRT, "Laterality")	CODE	1	U					DCID 244 "Laterality" Not used in AIM.

55
56

DICOM SR Path	DICOM VT	DICOM VM	DICOM Usage Type	Generated Value	AIM Element or Attribute	AIM Data Type	AIM Multiplicity	Comment
(126000, DCM, "Imaging Measurement Report") > (126010, DCM, "Imaging Measurements") > (125007, DCM, "Measurement Group") > (G-C0E3, SRT, "Finding Site") > (G-A1F8, SRT, "Topographical modifier")	CODE	1	U					Not used since AIM does not have a mechanism for post-coordinating the location.
(126000, DCM, "Imaging Measurement Report") > (126010, DCM, "Imaging Measurements") > (125007, DCM, "Measurement Group") > (126100, DCM, "Real World Value Map used for measurement")	COMPOSITE	1	U					Not used in AIM.
(126000, DCM, "Imaging Measurement Report") > (126010, DCM, "Imaging Measurements") > (125007, DCM, "Measurement Group") >	INCLUDE	1-n	M	TID 300 "Mapping of Measurement"				
(126000, DCM, "Imaging Measurement Report") > (126010, DCM, "Imaging Measurements") > (125007, DCM, "Measurement Group") > \$QualitativeEvaluations	CODE	1-n	U					Not used in AIM.
(126000, DCM, "Imaging Measurement Report") > (126010, DCM, "Imaging Measurements") > (125007, DCM, "Measurement Group") > \$QualitativeEvaluations	TEXT	1-n	U					Not used in AIM.

52 **TID 1502 Mapping of Time Point Context**

53 This section describes the mapping of PS3.16 TID 1502 "Time Point Context".

54

Table TID 1502. Mapping of Time Point Context

DICOM SR Path	DICOM VT	DICOM VM	DICOM Usage Type	Generated Value	AIM Element or Attribute	AIM Data Type	AIM Multiplicity	Comment
(126000, DCM, "Imaging Measurement Report") > (126010, DCM, "Imaging Measurements") > (125007, DCM, "Measurement Group") > (126070, DCM, "Subject Time Point Identifier")	TEXT	1	U					Not used in AIM.
(126000, DCM, "Imaging Measurement Report") > (126010, DCM, "Imaging Measurements") > (125007, DCM, "Measurement Group") > (126071, DCM, "Protocol Time Point Identifier")	TEXT	1	U					Not used in AIM.
(126000, DCM, "Imaging Measurement Report") > (126010, DCM, "Imaging Measurements") > (125007, DCM, "Measurement Group") > (C2348792, UMLS, "Time Point")	TEXT	1	M					Not used in AIM.
(126000, DCM, "Imaging Measurement Report") > (126010, DCM, "Imaging Measurements") > (125007, DCM, "Measurement Group") > (126072, DCM, "Time Point Type")	CODE	1-n	U					BCID 6146 "Time Point Types" Not used in AIM.
(126000, DCM, "Imaging Measurement Report") > (126010, DCM, "Imaging Measurements") > (125007, DCM, "Measurement Group") > (126073, DCM, "Time Point Order")	NUM	1	U					Not used in AIM.
(126000, DCM, "Imaging Measurement Report") > (126010, DCM, "Imaging Measurements") > (125007, DCM, "Measurement Group") > (128740, DCM, "Longitudinal Temporal Offset from Event")	NUM	1	U					Not used in AIM.
(126000, DCM, "Imaging Measurement Report") > (126010, DCM, "Imaging Measurements") > (125007, DCM, "Measurement Group") > (128740, DCM, "Longitudinal Temporal Offset from Event") > (128741, DCM, "Longitudinal Temporal Event Type")	CODE	1	U					Not used in AIM.

TID 1410 Mapping of Planar ROI Measurements

This section describes the mapping of PS3.16 TID 1410 "Planar ROI Measurements".

Table TID 1410. Mapping of Planar ROI Measurements

DICOM SR Path	DICOM VT	DICOM VM	DICOM Usage Type	Generated Value	AIM Element or Attribute	AIM Data Type	AIM Multiplicity	Comment
(126000, DCM, "Imaging Measurement Report") > (126010, DCM, "Imaging Measurements") > (125007, DCM, "Measurement Group")	CONTAINER	1	M					
(126000, DCM, "Imaging Measurement Report") > (126010, DCM, "Imaging Measurements") > (125007, DCM, "Measurement Group") > (C67447, NCI, "Activity Session")	TEXT	1	U					Not present in AIM. Identifies the session during which the measurements were made. The NCI Thesaurus definition is "time, period, or term devoted to some activity".
(126000, DCM, "Imaging Measurement Report") > (126010, DCM, "Imaging Measurements") > (125007, DCM, "Measurement Group") > (112039, DCM, "Tracking Identifier")	TEXT	1	M		ImageAnnotationCollection/imageAnnotations/ImageAnnotation/name/@value	ST	1	
(126000, DCM, "Imaging Measurement Report") > (126010, DCM, "Imaging Measurements") > (125007, DCM, "Measurement Group") > (112040, DCM, "Tracking Unique Identifier")	UIDREF	1	M		ImageAnnotationCollection/imageAnnotations/ImageAnnotation/uniqueIdentifier/@root	II	1	Using Image Annotation/uniqueIdentifier as a proxy for Tracking Unique Identifier does not allow longitudinal identification of the same lesion because Image Annotation/uniqueIdentifier must be unique to each AIM annotation file; only Image Annotation/name can be used to recognize commonality.

DICOM SR Path	DICOM VT	DICOM VM	DICOM Usage Type	Generated Value	AIM Element or Attribute	AIM Data Type	AIM Multiplicity	Comment
(126000, DCM, "Imaging Measurement Report") > (126010, DCM, "Imaging Measurements") > (125007, DCM, "Measurement Group") > (121071, DCM, "Finding")	CODE	1	U		ImageAnnotationCollection/imageAnnotations/ImageAnnotation/typeCode	CD	1..n	Only a single aim:typeCode value can be mapped.
(126000, DCM, "Imaging Measurement Report") > (126010, DCM, "Imaging Measurements") > (125007, DCM, "Measurement Group") >	INCLUDE	1	U	TID 1502 "Mapping of Time Point Context"				Not used in AIM.
(126000, DCM, "Imaging Measurement Report") > (126010, DCM, "Imaging Measurements") > (125007, DCM, "Measurement Group") > (111030, DCM, "Image Region")	SCCOORD	1	MC		ImageAnnotationCollection/imageAnnotations/ImageAnnotation/markupEntityCollection/MarkupEntity/twoDimensionSpatialCoordinateCollection/TwoDimensionSpatialCoordinate			A Graphic Type of MULTIPOINT is not permitted in the DICOM template.
(126000, DCM, "Imaging Measurement Report") > (126010, DCM, "Imaging Measurements") > (125007, DCM, "Measurement Group") > (111030, DCM, "Image Region") > IMAGE	IMAGE	1	M		ImageAnnotationCollection/imageAnnotations/ImageAnnotation/markupEntityCollection/MarkupEntity/imageReferenceUid/@root, referencedFrameNumber/@value	II, INT	1, 0..1	The Referenced SOP Class UID is obtained from imageReferenceEntityCollection; see Table A.8-5
(126000, DCM, "Imaging Measurement Report") > (126010, DCM, "Imaging Measurements") > (125007, DCM, "Measurement Group") > (121214, DCM, "Referenced Segmentation Frame")	IMAGE	1	MC		ImageAnnotationCollection/imageAnnotations/ImageAnnotation/segmentationEntityCollection/SegmentationEntity			Reference shall be to a Segmentation Image, with a single value specified in Referenced Frame Number, and with a single value specified in Referenced Segment Number

DICOM SR Path	DICOM VT	DICOM VM	DICOM Usage Type	Generated Value	AIM Element or Attribute	AIM Data Type	AIM Multiplicity	Comment
(126000, DCM, "Imaging Measurement Report") > (126010, DCM, "Imaging Measurements") > (125007, DCM, "Measurement Group") > (121233, DCM, "Source image for segmentation")	IMAGE	1	MC		ImageAnnotationCollection/imageAnnotations/ImageAnnotation/segmentationEntityCollection/SegmentationEntity/referencedSopInstanceUid/@root			
(126000, DCM, "Imaging Measurement Report") > (126010, DCM, "Imaging Measurements") > (125007, DCM, "Measurement Group") > (121200, DCM, "Illustration of ROI")	IMAGE	1	U					Not used in AIM.
(126000, DCM, "Imaging Measurement Report") > (126010, DCM, "Imaging Measurements") > (125007, DCM, "Measurement Group") > (126100, DCM, "Real World Value Map used for measurement")	COMPOSITE	1	U					Not used in AIM.
(126000, DCM, "Imaging Measurement Report") > (126010, DCM, "Imaging Measurements") > (125007, DCM, "Measurement Group") >	INCLUDE	1	M	TID 1419 "Mapping of ROI Measurements"				Not used in AIM.
(126000, DCM, "Imaging Measurement Report") > (126010, DCM, "Imaging Measurements") > (125007, DCM, "Measurement Group") > \$QualitativeEvaluations	CODE	1-n	U					Not used in AIM.

DICOM SR Path	DICOM VT	DICOM VM	DICOM Usage Type	Generated Value	AIM Element or Attribute	AIM Data Type	AIM Multiplicity	Comment
(126000, DCM, "Imaging Measurement Report") > (126010, DCM, "Imaging Measurements") > (125007, DCM, "Measurement Group") > \$QualitativeEvaluations	TEXT	1-n	U					Not used in AIM.

TID 1411 Mapping of Volumetric ROI Measurements

This section describes the mapping of PS3.16 TID 1411 "Volumetric ROI Measurements".

Table TID 1411. Mapping of Volumetric ROI Measurements

DICOM SR Path	DICOM VT	DICOM VM	DICOM Usage Type	Generated Value	AIM Element or Attribute	AIM Data Type	AIM Multiplicity	Comment
(126000, DCM, "Imaging Measurement Report") > (126010, DCM, "Imaging Measurements") > (125007, DCM, "Measurement Group")	CONTAINER	1	M					
(126000, DCM, "Imaging Measurement Report") > (126010, DCM, "Imaging Measurements") > (125007, DCM, "Measurement Group") > (C67447, NCIt, "Activity Session")	TEXT	1	U					Not present in AIM. Identifies the session during which the measurements were made. The NCI Thesaurus definition is "time, period, or term devoted to some activity".
(126000, DCM, "Imaging Measurement Report") > (126010, DCM, "Imaging Measurements") > (125007, DCM, "Measurement Group") > (112039, DCM, "Tracking Identifier")	TEXT	1	M		ImageAnnotationCollection/imageAnnotations/ImageAnnotation/name/@value	ST	1	

DICOM SR Path	DICOM VT	DICOM VM	DICOM Usage Type	Generated Value	AIM Element or Attribute	AIM Data Type	AIM Multiplicity	Comment
(126000, DCM, "Imaging Measurement Report") > (126010, DCM, "Imaging Measurements") > (125007, DCM, "Measurement Group") > (112040, DCM, "Tracking Unique Identifier")	UIDREF	1	M		ImageAnnotationCollection/imageAnnotations/ImageAnnotation/uniqueIdentifier/@root	II	1	Using Image Annotation/uniqueIdentifier as a proxy for Tracking Unique Identifier does not allow longitudinal identification of the same lesion because Image Annotation/uniqueIdentifier must be unique to each AIM annotation file; only Image Annotation/name can be used to recognize commonality.
(126000, DCM, "Imaging Measurement Report") > (126010, DCM, "Imaging Measurements") > (125007, DCM, "Measurement Group") > (121071, DCM, "Finding")	CODE	1	U		ImageAnnotationCollection/imageAnnotations/ImageAnnotation/typeCode	CD	1..n	Only a single aim:typeCode value can be mapped.
(126000, DCM, "Imaging Measurement Report") > (126010, DCM, "Imaging Measurements") > (125007, DCM, "Measurement Group") >	INCLUDE	1	U	TID 1502 "Mapping of Time Point Context"				Not used in AIM.
(126000, DCM, "Imaging Measurement Report") > (126010, DCM, "Imaging Measurements") > (125007, DCM, "Measurement Group") > (111030, DCM, "Image Region")	SCoord	1-n	MC		ImageAnnotationCollection/imageAnnotations/ImageAnnotation/markupEntityCollection/MarkupEntity/twoDimensionSpatialCoordinateCollection/TwoDimensionSpatialCoordinate	REAL	1..n	A Graphic Type of MULTIPOINT is not permitted in the DICOM template.

DICOM SR Path	DICOM VT	DICOM VM	DICOM Usage Type	Generated Value	AIM Element or Attribute	AIM Data Type	AIM Multiplicity	Comment
(126000, DCM, "Imaging Measurement Report") > (126010, DCM, "Imaging Measurements") > (125007, DCM, "Measurement Group") > (111030, DCM, "Image Region") > IMAGE	IMAGE	1	M		ImageAnnotationCollection/imageAnnotations/ImageAnnotation/markupEntityCollection/MarkupEntity/imageReferenceUid/@root, referencedFrameNumber/@value	II, INT	1, 0..1	The Referenced SOP Class UID is obtained from imageReferenceEntityCollection; see Table A.8-5
(126000, DCM, "Imaging Measurement Report") > (126010, DCM, "Imaging Measurements") > (125007, DCM, "Measurement Group") > (121191, DCM, "Referenced Segment")	IMAGE	1	MC		ImageAnnotationCollection/imageAnnotations/ImageAnnotation/segmentationEntityCollection/SegmentationEntity	INT	0..1	Reference shall be to a Segmentation Image or Surface Segmentation object, with a single value specified in Referenced Segment Number
(126000, DCM, "Imaging Measurement Report") > (126010, DCM, "Imaging Measurements") > (125007, DCM, "Measurement Group") > (121231, DCM, "Volume Surface")	SCoord3D	1	MC					Not used in AIM.
(126000, DCM, "Imaging Measurement Report") > (126010, DCM, "Imaging Measurements") > (125007, DCM, "Measurement Group") > (121233, DCM, "Source image for segmentation")	IMAGE	1-n	MC		ImageAnnotationCollection/imageAnnotations/ImageAnnotation/segmentationEntityCollection/SegmentationEntity/referencedSopInstanceUid/@root			
(126000, DCM, "Imaging Measurement Report") > (126010, DCM, "Imaging Measurements") > (125007, DCM, "Measurement Group") > (121232, DCM, "Source series for segmentation")	UIDREF	1	MC					Not used in AIM

DICOM SR Path	DICOM VT	DICOM VM	DICOM Usage Type	Generated Value	AIM Element or Attribute	AIM Data Type	AIM Multiplicity	Comment
(126000, DCM, "Imaging Measurement Report") > (126010, DCM, "Imaging Measurements") > (125007, DCM, "Measurement Group") > (121200, DCM, "Illustration of ROI")	IMAGE	1-n	U					Not used in AIM.
(126000, DCM, "Imaging Measurement Report") > (126010, DCM, "Imaging Measurements") > (125007, DCM, "Measurement Group") > (126100, DCM, "Real World Value Map used for measurement")	COMPOSITE	1	U					Not used in AIM.
(126000, DCM, "Imaging Measurement Report") > (126010, DCM, "Imaging Measurements") > (125007, DCM, "Measurement Group") >	INCLUDE	1	M	TID 1419 "Mapping of ROI Measurements"				
(126000, DCM, "Imaging Measurement Report") > (126010, DCM, "Imaging Measurements") > (125007, DCM, "Measurement Group") > \$QualitativeEvaluations	CODE	1-n	U		ImageAnnotationCollection/ imageAnnotations/Image Annotation/imaging ObservationEntityCollection/ ImagingObservationEntity/ imagingObservation CharacteristicCollection/ ImagingObservation Characteristic/questionType Code,typeCode	CD, CD	1, 0..1	
(126000, DCM, "Imaging Measurement Report") > (126010, DCM, "Imaging Measurements") > (125007, DCM, "Measurement Group") > \$QualitativeEvaluations	TEXT	1-n	U					Not used in AIM.

TID 1419 Mapping of ROI Measurements

This section describes the mapping of PS3.16 TID 1419 "ROI Measurements".

Table TID 1419. Mapping of ROI Measurements

DICOM SR Path	DICOM VT	DICOM VM	DICOM Usage Type	Generated Value	AIM Element or Attribute	AIM Data Type	AIM Multiplicity	Comment
(126000, DCM, "Imaging Measurement Report") > (126010, DCM, "Imaging Measurements") > (125007, DCM, "Measurement Group") > (G-C036, SRT, "Measurement Method")	CODE	1	U					Not encoded in AIM at this level.
(126000, DCM, "Imaging Measurement Report") > (126010, DCM, "Imaging Measurements") > (125007, DCM, "Measurement Group") > (G-C0E3, SRT, "Finding Site")	CODE	1-n	U		ImageAnnotation Collection/image Annotations/Image Annotation/ imagingPhysicalEntity Collection/ ImagingPhysicalEntity [label/ @value='Location' or label/@value='Lobar Location' or label/ @value='Segmental Location' or label/ @value='Organ Type']/typeCode	CD	1..n	The finding site is factored out since it is common to all measurements in this group. If a paired structure in AIM, this entry will pre-coordinate the laterality with the site.
(126000, DCM, "Imaging Measurement Report") > (126010, DCM, "Imaging Measurements") > (125007, DCM, "Measurement Group") > (G-C0E3, SRT, "Finding Site") > (G-C171, SRT, "Laterality")	CODE	1	U					Not used since AIM does not have a mechanism for post-coordinating the location.
(126000, DCM, "Imaging Measurement Report") > (126010, DCM, "Imaging Measurements") > (125007, DCM, "Measurement Group") > (G-C0E3, SRT, "Finding Site") > (G-A1F8, SRT, "Topographical modifier")	CODE	1	U					Not used since AIM does not have a mechanism for post-coordinating the location.

65
66

1
2
3
4
5
6
7
8
9
10
11
12
13
14
15
16
17
18
19
20
21
22
23
24
25
26
27
28
29
30
31
32
33
34
35
36
37
38
39
40
41
42
43
44
45
46
47
48
49
50
51
52
53
54
55
56
57
58
59
60
61
62
63

DICOM SR Path	DICOM VT	DICOM VM	DICOM Usage Type	Generated Value	AIM Element or Attribute	AIM Data Type	AIM Multiplicity	Comment
(126000, DCM, "Imaging Measurement Report") > (126010, DCM, "Imaging Measurements") > (125007, DCM, "Measurement Group") > \$Measurement	NUM	1-n	M		<p>NAME = Image AnnotationCollection/ imageAnnotations/ ImageAnnotation/ calculationEntity Collection/ CalculationEntity/ typeCode[1]</p> <p>VALUE = Image AnnotationCollection/ imageAnnotations/ ImageAnnotation/ calculationEntity Collection/ CalculationEntity/ calculationResult Collection/ CalculationResult/ @value, calculationData Collection/ CalculationData/ @value</p> <p>UNITS = Image AnnotationCollection/ imageAnnotations/ ImageAnnotation/ calculationEntity Collection/ CalculationEntity/ calculationResult Collection/ CalculationResult/ unitOfMeasure</p>	CD, ST, CD	1..n, 0..n, 1	<p>The first typeCode entry is assumed to be the primary concept. Other typeCode entries may be considered as modifiers.</p> <p>Value may be found in either Compact CalculationResult (i.e., value child of CalculationResult) or first value of Extended CalculationResult (i.e., nested within calculationResult Collection).</p> <p>Only mapping of a single value from Extended CalculationResult is supported.</p> <p>If no measurement is present in AIM (0..n) then do not include the template in the first place.</p>
(126000, DCM, "Imaging Measurement Report") > (126010, DCM, "Imaging Measurements") > (125007, DCM, "Measurement Group") > \$Measurement > \$ModType	CODE	1-n	U		ImageAnnotation Collection/image Annotations/Image Annotation/calculation EntityCollection/ CalculationEntity/ typeCode[position() != 1]	CD	1..n	The first typeCode entry is assumed to be the primary concept. This row can be used if successive typeCode entries are recognized, and not a method or derivation, and a name-value pair can be constructed from the typeCode entry (which is a single code).

64

DICOM SR Path	DICOM VT	DICOM VM	DICOM Usage Type	Generated Value	AIM Element or Attribute	AIM Data Type	AIM Multiplicity	Comment
(126000, DCM, "Imaging Measurement Report") > (126010, DCM, "Imaging Measurements") > (125007, DCM, "Measurement Group") > \$Measurement > (G-C036, SRT, "Measurement Method")	CODE	1	U		ImageAnnotationCollection/imageAnnotations/ImageAnnotation/calculationEntityCollection/CalculationEntity/typeCode[position() != 1]	CD	1..n	The first typeCode entry is assumed to be the primary concept. Other typeCode entries may be considered as modifiers, but there is no standard order, so recognition as a "method" depends on recognition of specific codes.
(126000, DCM, "Imaging Measurement Report") > (126010, DCM, "Imaging Measurements") > (125007, DCM, "Measurement Group") > \$Measurement > (121401, DCM, "Derivation")	CODE	1	U		ImageAnnotationCollection/imageAnnotations/ImageAnnotation/calculationEntityCollection/CalculationEntity/typeCode[position() != 1]	CD	1..n	The first typeCode entry is assumed to be the primary concept. Other typeCode entries may be considered as modifiers, but there is no standard order, so recognition as a "derivation" depends on recognition of specific codes.
(126000, DCM, "Imaging Measurement Report") > (126010, DCM, "Imaging Measurements") > (125007, DCM, "Measurement Group") > \$Measurement > (G-C0E3, SRT, "Finding Site")	CODE	1-n	U					Not used, since is sent at measurement group level since common to all measurements in annotation. If a paired structure in AIM, this entry will pre-coordinate the laterality with the site.
(126000, DCM, "Imaging Measurement Report") > (126010, DCM, "Imaging Measurements") > (125007, DCM, "Measurement Group") > \$Measurement > (G-C0E3, SRT, "Finding Site") > (G-C171, SRT, "Laterality")	CODE	1	U					CID 244 "Laterality"

53
54

1
2
3
4
5
6
7
8
9
10
11
12
13
14
15
16
17
18
19
20
21
22
23
24
25
26
27
28
29
30
31
32
33
34
35
36
37
38
39
40
41
42
43
44
45
46
47
48
49
50
51

DICOM SR Path	DICOM VT	DICOM VM	DICOM Usage Type	Generated Value	AIM Element or Attribute	AIM Data Type	AIM Multiplicity	Comment
(126000, DCM, "Imaging Measurement Report") > (126010, DCM, "Imaging Measurements") > (125007, DCM, "Measurement Group") > \$Measurement > (G-C0E3, SRT, "Finding Site") > (G-A1F8, SRT, "Topographical modifier")	CODE	1	U					Not used since AIM does not have a mechanism for post-coordinating the location.
(126000, DCM, "Imaging Measurement Report") > (126010, DCM, "Imaging Measurements") > (125007, DCM, "Measurement Group") > \$Measurement >	INCLUDE	1	U	TID 310 "Measurement Properties"				Statistical and normal range properties are not used in AIM use cases for this mapping.
(126000, DCM, "Imaging Measurement Report") > (126010, DCM, "Imaging Measurements") > (125007, DCM, "Measurement Group") > \$Measurement > \$DerivationParameter	NUM	1-n	UC					Not used in AIM
(126000, DCM, "Imaging Measurement Report") > (126010, DCM, "Imaging Measurements") > (125007, DCM, "Measurement Group") > \$Measurement > \$DerivationParameter	NUM	1-n	UC					Not used in AIM
(126000, DCM, "Imaging Measurement Report") > (126010, DCM, "Imaging Measurements") > (125007, DCM, "Measurement Group") > \$Measurement >	INCLUDE	1	UC	TID 315 "Equation or Table"				Not used in AIM
(126000, DCM, "Imaging Measurement Report") > (126010, DCM, "Imaging Measurements") > (125007, DCM, "Measurement Group") > \$Measurement > TEXT	TEXT	1	UC					CID 228 "Equation or Table" Not used in AIM

52

DICOM SR Path	DICOM VT	DICOM VM	DICOM Usage Type	Generated Value	AIM Element or Attribute	AIM Data Type	AIM Multiplicity	Comment
(126000, DCM, "Imaging Measurement Report") > (126010, DCM, "Imaging Measurements") > (125007, DCM, "Measurement Group") > \$Measurement >	INCLUDE	1	U	TID 1000 "Quotation"				Quotations are not used in AIM.
(126000, DCM, "Imaging Measurement Report") > (126010, DCM, "Imaging Measurements") > (125007, DCM, "Measurement Group") > \$Measurement > (121050, DCM, "Equivalent Meaning of Concept Name")	TEXT	1	U					Not used in AIM.
(126000, DCM, "Imaging Measurement Report") > (126010, DCM, "Imaging Measurements") > (125007, DCM, "Measurement Group") > \$Measurement > (126100, DCM, "Real World Value Map used for measurement")	COMPOSITE	1	U					Not used in AIM.
(126000, DCM, "Imaging Measurement Report") > (126010, DCM, "Imaging Measurements") > (125007, DCM, "Measurement Group") > \$Measurement >	INCLUDE	1	U	TID 4019 "Mapping of Algorithm Identification"				

TID 1420 Mapping of Measurements Derived From Multiple ROI Measurements

This section describes the mapping of PS3.16 TID 1420 "Measurements Derived From Multiple ROI Measurements".

Table TID 1420. Mapping of Measurements Derived From Multiple ROI Measurements

DICOM SR Path	DICOM VT	DICOM VM	DICOM Usage Type	Generated Value	AIM Element or Attribute	AIM Data Type	AIM Multiplicity	Comment
(126000, DCM, "Imaging Measurement Report") > (126011, DCM, "Derived Imaging Measurements") > NUM	NUM	1-n	M					CID 7465 "Measurements Derived From Multiple ROI Measurements"
(126000, DCM, "Imaging Measurement Report") > (126011, DCM, "Derived Imaging Measurements") > NUM >	INCLUDE	1-n	MC	TID 1410 "Mapping of Planar ROI Measurements"				

DICOM SR Path	DICOM VT	DICOM VM	DICOM Usage Type	Generated Value	AIM Element or Attribute	AIM Data Type	AIM Multiplicity	Comment
(126000, DCM, "Imaging Measurement Report") > (126011, DCM, "Derived Imaging Measurements") > NUM >	INCLUDE	1-n	MC	TID 1411 "Mapping of Volumetric ROI Measurements"				
(126000, DCM, "Imaging Measurement Report") > (126011, DCM, "Derived Imaging Measurements") > NUM >	INCLUDE	1	U	TID 310 "Measurement Properties"				Statistical and normal range properties are not used in AIM use cases for this mapping.

TID 300 Mapping of Measurement

This section describes the mapping of PS3.16 TID 300 "Measurement".

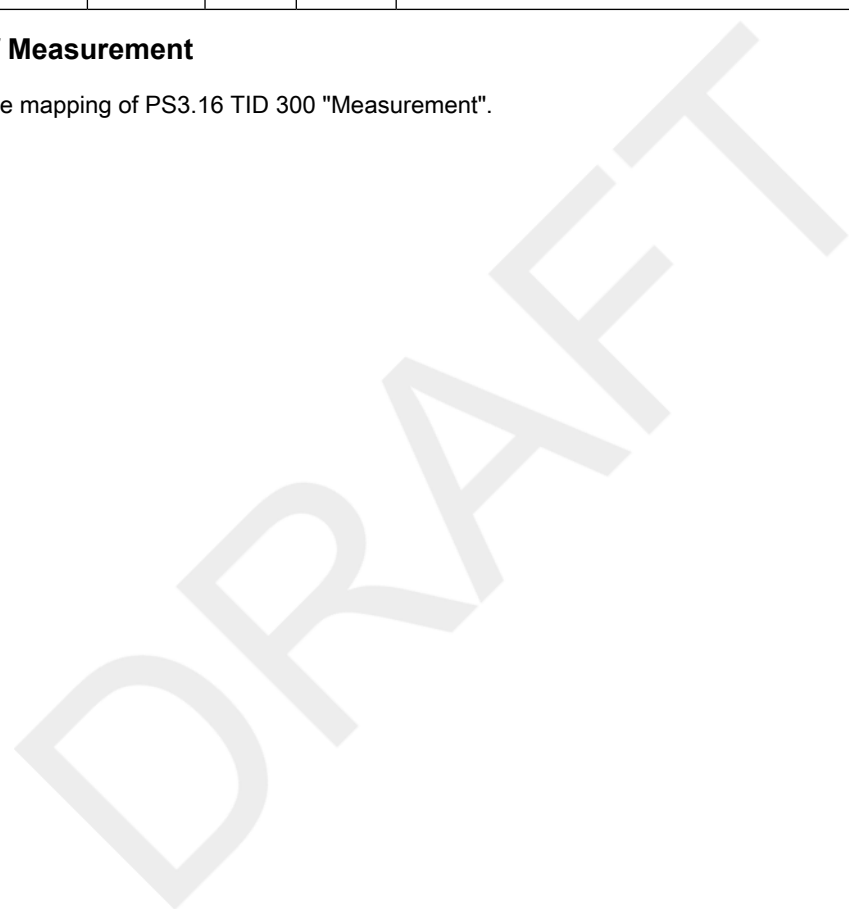

17
18

1
2
3
4
5
6
7
8
9
10
11
12
13

14
15

Table TID 300. Mapping of Measurement

DICOM SR Path	DICOM VT	DICOM VM	DICOM Usage Type	Generated Value	AIM Element or Attribute	AIM Data Type	AIM Multiplicity	Comment
(126000, DCM, "Imaging Measurement Report") > (126010, DCM, "Imaging Measurements") > (125007, DCM, "Measurement Group") > \$Measurement	NUM	1	M		<p>NAME = Image Annotation Collection/image Annotations/Image Annotation/calculationEntity Collection/CalculationEntity/typeCode[1]</p> <p>VALUE = Image Annotation Collection/image Annotations/Image Annotation/calculationEntity Collection/CalculationEntity/calculationResult Collection/CalculationResult/@value, calculationData Collection/CalculationData/@value</p> <p>UNITS = Image Annotation Collection/image Annotations/Image Annotation/calculationEntity Collection/CalculationEntity/calculationResult Collection/CalculationResult/unitOfMeasure</p>	CD, ST, CD	1..n, 0..n, 1	<p>The first typeCode entry is assumed to be the primary concept. Other typeCode entries may be considered as modifiers.</p> <p>Value may be found in either Compact CalculationResult (i.e., value child of CalculationResult) or first value of Extended CalculationResult (i.e., nested within calculationResult Collection).</p> <p>Only mapping of a single value from Extended CalculationResult is supported.</p>
(126000, DCM, "Imaging Measurement Report") > (126010, DCM, "Imaging Measurements") > (125007, DCM, "Measurement Group") > \$Measurement > \$ModType	CODE	1-n	U		ImageAnnotation Collection/image Annotations/Image Annotation/calculationEntity Collection/CalculationEntity/typeCode [position() != 1]	CD	1..n	The first typeCode entry is assumed to be the primary concept. This row can be used if successive typeCode entries are recognized, and not a method or derivation, and a name-value pair can be constructed from the typeCode entry (which is a single code).

DICOM SR Path	DICOM VT	DICOM VM	DICOM Usage Type	Generated Value	AIM Element or Attribute	AIM Data Type	AIM Multiplicity	Comment
(126000, DCM, "Imaging Measurement Report") > (126010, DCM, "Imaging Measurements") > (125007, DCM, "Measurement Group") > \$Measurement > (G-C036, SRT, "Measurement Method")	CODE	1	U		ImageAnnotationCollection/imageAnnotations/ImageAnnotation/calculationEntityCollection/CalculationEntity/typeCode [position() != 1]	CD	1..n	The first typeCode entry is assumed to be the primary concept. Other typeCode entries may be considered as modifiers, but there is no standard order, so recognition as a "method" depends on recognition of specific codes.
(126000, DCM, "Imaging Measurement Report") > (126010, DCM, "Imaging Measurements") > (125007, DCM, "Measurement Group") > \$Measurement > (121401, DCM, "Derivation")	CODE	1	U		ImageAnnotationCollection/imageAnnotations/ImageAnnotation/calculationEntityCollection/CalculationEntity/typeCode [position() != 1]	CD	1..n	The first typeCode entry is assumed to be the primary concept. Other typeCode entries may be considered as modifiers, but there is no standard order, so recognition as a "derivation" depends on recognition of specific codes.
(126000, DCM, "Imaging Measurement Report") > (126010, DCM, "Imaging Measurements") > (125007, DCM, "Measurement Group") > \$Measurement > (G-C0E3, SRT, "Finding Site")	CODE	1-n	U					Not used in AIM, since it is sent at measurement group level because it is common to all measurements in annotation.
(126000, DCM, "Imaging Measurement Report") > (126010, DCM, "Imaging Measurements") > (125007, DCM, "Measurement Group") > \$Measurement > (G-C0E3, SRT, "Finding Site") > (G-C171, SRT, "Laterality")	CODE	1	U		CID 244 "Laterality"			Not used in AIM.
(126000, DCM, "Imaging Measurement Report") > (126010, DCM, "Imaging Measurements") > (125007, DCM, "Measurement Group") > \$Measurement > (G-C0E3, SRT, "Finding Site") > (G-A1F8, SRT, "Topographical modifier")	CODE	1	U		\$TargetSiteMod			Not used since AIM does not have a mechanism for post-coordinating the location.

DICOM SR Path	DICOM VT	DICOM VM	DICOM Usage Type	Generated Value	AIM Element or Attribute	AIM Data Type	AIM Multiplicity	Comment
(126000, DCM, "Imaging Measurement Report") > (126010, DCM, "Imaging Measurements") > (125007, DCM, "Measurement Group") > \$Measurement >	INCLUDE	1	U	TID 310 "Measurement Properties"				Statistical and normal range properties are not used in AIM use cases for this mapping.
(126000, DCM, "Imaging Measurement Report") > (126010, DCM, "Imaging Measurements") > (125007, DCM, "Measurement Group") > \$Measurement > \$DerivationParameter	NUM	1-n	UC					Not used in AIM for our use cases.
(126000, DCM, "Imaging Measurement Report") > (126010, DCM, "Imaging Measurements") > (125007, DCM, "Measurement Group") > \$Measurement > \$DerivationParameter	NUM	1-n	UC					Not used in AIM for our use cases.
(126000, DCM, "Imaging Measurement Report") > (126010, DCM, "Imaging Measurements") > (125007, DCM, "Measurement Group") > \$Measurement >	INCLUDE	1	UC	TID 315 "Equation or Table"				Beyond the scope of our use cases to map.
(126000, DCM, "Imaging Measurement Report") > (126010, DCM, "Imaging Measurements") > (125007, DCM, "Measurement Group") > \$Measurement > TEXT	TEXT	1	UC					DCID 228 "Equation or Table" Beyond the scope of our use cases to map.
(126000, DCM, "Imaging Measurement Report") > (126010, DCM, "Imaging Measurements") > (125007, DCM, "Measurement Group") > \$Measurement > \$ImagePurpose	INCLUDE	1-n	U	TID 320 "Mapping of Image or Spatial Coordinates"				
(126000, DCM, "Imaging Measurement Report") > (126010, DCM, "Imaging Measurements") > (125007, DCM, "Measurement Group") > \$Measurement > \$WavePurpose	INCLUDE	1-n	U	TID 321 "Waveform or Temporal Coordinates"				Not used in our AIM use cases.
(126000, DCM, "Imaging Measurement Report") > (126010, DCM, "Imaging Measurements") > (125007, DCM, "Measurement Group") > \$Measurement >	INCLUDE	1	U	TID 1000 "Quotation"				Not used in our AIM use cases.

DICOM SR Path	DICOM VT	DICOM VM	DICOM Usage Type	Generated Value	AIM Element or Attribute	AIM Data Type	AIM Multiplicity	Comment
(126000, DCM, "Imaging Measurement Report") > (126010, DCM, "Imaging Measurements") > (125007, DCM, "Measurement Group") > \$Measurement > (121050, DCM, "Equivalent Meaning of Concept Name")	TEXT	1	U					Not used in AIM
(126000, DCM, "Imaging Measurement Report") > (126010, DCM, "Imaging Measurements") > (125007, DCM, "Measurement Group") > \$Measurement >	INCLUDE	1	U	TID 4108 "Mapping of Tracking Identifier"				Not mapped at this level for TID 1500, but rather at the Measurement Group level in TID 1501.
(126000, DCM, "Imaging Measurement Report") > (126010, DCM, "Imaging Measurements") > (125007, DCM, "Measurement Group") > \$Measurement > (126100, DCM, "Real World Value Map used for measurement")	COMPOSITE	1	U					Not used in AIM.
(126000, DCM, "Imaging Measurement Report") > (126010, DCM, "Imaging Measurements") > (125007, DCM, "Measurement Group") > \$Measurement >	INCLUDE	1	U	TID 4019 "Mapping of Algorithm Identification"				

TID 320 Mapping of Image or Spatial Coordinates

This section describes the mapping of PS3.16 TID 320 "Image or Spatial Coordinates".

Table TID 320. Mapping of Image or Spatial Coordinates

DICOM SR Path	DICOM VT	DICOM VM	DICOM Usage Type	Generated Value	AIM Element or Attribute	AIM Data Type	AIM Multiplicity	Comment
(126000, DCM, "Imaging Measurement Report") > (126010, DCM, "Imaging Measurements") > (125007, DCM, "Measurement Group") > \$Purpose	IMAGE	1	MC		ImageAnnotationCollection/imageAnnotations/ImageAnnotation/markupEntityCollection/MarkupEntity/imageReferenceUid/@root, referencedFrameNumber/@value	II, INT	1, 0..1	An entire image reference without spatial coordinates The Referenced SOP Class UID is obtained from imageReferenceEntityCollection; see Table A.8-5 Only the by-value (SELECTED FROM) relationship is used, not the by-reference (R-SELECTED FROM) relationship.
(126000, DCM, "Imaging Measurement Report") > (126010, DCM, "Imaging Measurements") > (125007, DCM, "Measurement Group") > \$Purpose	SCCOORD	1	MC		ImageAnnotationCollection/imageAnnotations/ImageAnnotation/markupEntityCollection/MarkupEntity/twoDimensionSpatialCoordinateCollection/TwoDimensionSpatialCoordinate	REAL	1..n	A reference to coordinates on an image.
(126000, DCM, "Imaging Measurement Report") > (126010, DCM, "Imaging Measurements") > (125007, DCM, "Measurement Group") > \$Purpose > IMAGE	IMAGE	1	M		ImageAnnotationCollection/imageAnnotations/ImageAnnotation/markupEntityCollection/MarkupEntity/imageReferenceUid/@root, referencedFrameNumber/@value	II, INT	1, 0..1	The Referenced SOP Class UID is obtained from imageReferenceEntityCollection; see Table A.8-5 Only the by-value (SELECTED FROM) relationship is used, not the by-reference (R-SELECTED FROM) relationship.

TID 4019 Mapping of Algorithm Identification

This section describes the mapping of PS3.16 TID 4019 "~~GAD~~Algorithm Identification".

Table TID 4019. Mapping of Algorithm Identification

DICOM SR Path	DICOM VT	DICOM VM	DICOM Usage Type	Generated Value	AIM Element or Attribute	AIM Data Type	AIM Multiplicity	Comment
(126000, DCM, "Imaging Measurement Report") > (126010, DCM, "Imaging Measurements") > (125007, DCM, "Measurement Group") > \$Measurement > (111001, DCM, "Algorithm Name")	TEXT	1	U		ImageAnnotationCollection/imageAnnotations/ImageAnnotation/calculationEntityCollection/CalculationEntity/algorithm/name/@value	ST	1	The type attribute (CD 1..n) is not supported by CID 4019
(126000, DCM, "Imaging Measurement Report") > (126010, DCM, "Imaging Measurements") > (125007, DCM, "Measurement Group") > \$Measurement > (111003, DCM, "Algorithm Version")	TEXT	1	U		ImageAnnotationCollection/imageAnnotations/ImageAnnotation/calculationEntityCollection/CalculationEntity/algorithm/version/@value	ST	0..1	
(126000, DCM, "Imaging Measurement Report") > (126010, DCM, "Imaging Measurements") > (125007, DCM, "Measurement Group") > \$Measurement > (111002, DCM, "Algorithm Parameters")	TEXT	1-n	U		ImageAnnotationCollection/imageAnnotations/ImageAnnotation/calculationEntityCollection/CalculationEntity/algorithm/parameter/@dataType,@name,@value	CD,ST,ST	0..n	Separate mapping of dataType, name and value attributes is not supported by CID 4019
					ImageAnnotationCollection/imageAnnotations/ImageAnnotation/calculationEntityCollection/CalculationEntity/algorithm/type	CD	1..n	No corresponding mapping in DICOM SR template at this time.

TID 4108 Mapping of Tracking Identifier

This section describes the mapping of PS3.16 TID 4108 "Tracking Identifier".

For the purpose of this mapping, this template is not used to track individual measurements; rather, the corresponding content items defined in Section TID 1501 "Mapping of Measurement Group" are mapped at the Measurement Group level instead.

Table TID 4108. Mapping of Tracking Identifier

DICOM SR Path	DICOM VT	DICOM VM	DICOM Usage Type	Generated Value	AIM Element or Attribute	AIM Data Type	AIM Multiplicity	Comment
(126000, DCM, "Imaging Measurement Report") > (126010, DCM, "Imaging Measurements") > (125007, DCM, "Measurement Group") > \$Measurement > (112039, DCM, "Tracking Identifier")	TEXT	1	U					MC but U in parent TID 300. Not mapped at this level for TID 1500, but rather at the Measurement Group level in TID 1501.
(126000, DCM, "Imaging Measurement Report") > (126010, DCM, "Imaging Measurements") > (125007, DCM, "Measurement Group") > \$Measurement > (112040, DCM, "Tracking Unique Identifier")	UIDREF	1	U					MC but U in parent TID 300. Not mapped at this level for TID 1500, but rather at the Measurement Group level in TID 1501.

TID 1204 Mapping of Language of Content Item and Descendants

This section describes the mapping of PS3.16 TID 1204 "Language of Content Item and Descendants".

Table TID 1204. Mapping of Language of Content Item and Descendants

DICOM SR Path	DICOM VT	DICOM VM	DICOM Usage Type	Generated Value	AIM Element or Attribute	AIM Data Type	AIM Multiplicity	Comment
(126000, DCM, "Imaging Measurement Report") > (121049, DCM, "Language of Content Item and Descendants")	CODE	1	M	(eng,RFC3066,"English")				Not used in AIM; discarded if present in DICOM SR. CID 5000 "Languages"
(126000, DCM, "Imaging Measurement Report") > (121049, DCM, "Language of Content Item and Descendants") > (121046, DCM, "Country of Language")	CODE	1	U	(US,ISO3166_1,"United States")				Not used in AIM; discarded if present in DICOM SR. CID 5001 "Countries"

TID 1001 Mapping of Observation Context

This section describes the mapping of PS3.16 TID 1001 "Observation Context".

Table TID 1001. Mapping of Observation Context

DICOM SR Path	DICOM VT	DICOM VM	DICOM Usage Type	Generated Value	AIM Element or Attribute	AIM Data Type	AIM Multiplicity	Comment
(126000, DCM, "Imaging Measurement Report") >	INCLUDE	1-n	MC	TID 1002 "Mapping of Observer Context"				Only required for AIM if attributes of the Author Observer Sequence (0040,A078) are insufficient to describe the person observer; not used for a device observer.
(126000, DCM, "Imaging Measurement Report") >	INCLUDE	1	MC	TID 1005 "Procedure Context"				Not used in AIM since redundant with header information; discarded if present in DICOM SR.
(126000, DCM, "Imaging Measurement Report") >	INCLUDE	1	MC	TID 1006 "Subject Context"				Not used in AIM since redundant with header information; discarded if present in DICOM SR.

TID 1002 Mapping of Observer Context

This section describes the mapping of PS3.16 TID 1002 "Observer Context".

Table TID 1002. Mapping of Observer Context

DICOM SR Path	DICOM VT	DICOM VM	DICOM Usage Type	Generated Value	AIM Element or Attribute	AIM Data Type	AIM Multiplicity	Comment
(126000, DCM, "Imaging Measurement Report") > (121005, DCM, "Observer Type")	CODE	1	MC					Since this template is only used for AIM for person observers, which is the default, it may be omitted or explicitly sent as (121006, DCM, "Person"); see also CID 270 "Observer Type"
(126000, DCM, "Imaging Measurement Report") >	INCLUDE	1	MC	TID 1003 "Mapping of Person Observer Identifying Attributes"				IFF Row 1 value = (121006, DCM, "Person") or Row 1 is absent
(126000, DCM, "Imaging Measurement Report") >	INCLUDE	1	MC	TID 1004 "Device Observer Identifying Attributes"				Not used in AIM; IFF Row 1 value = (121007, DCM, "Device")

TID 1003 Mapping of Person Observer Identifying Attributes

This section describes the mapping of PS3.16 TID 1003 "Person Observer Identifying Attributes".

Table TID 1003. Mapping of Person Observer Identifying Attributes

DICOM SR Path	DICOM VT	DICOM VM	DICOM Usage Type	Generated Value	AIM Element or Attribute	AIM Data Type	AIM Multiplicity	Comment
(126000, DCM, "Imaging Measurement Report") > (121008, DCM, "Person Observer Name")	PNAME	1	M		ImageAnnotationCollection/user/name/@value	ST	1..1	
(126000, DCM, "Imaging Measurement Report") > (128774, DCM, "Person Observer's Login Name")	PNAME	1	M		ImageAnnotationCollection/user/loginName/@value	ST	1..1	
(126000, DCM, "Imaging Measurement Report") > (121009, DCM, "Person Observer's Organization Name")	TEXT	1	U					Not used in AIM.
(126000, DCM, "Imaging Measurement Report") > (121010, DCM, "Person Observer's Role in the Organization")	CODE	1	U					Not used in AIM.
(126000, DCM, "Imaging Measurement Report") > (121011, DCM, "Person Observer's Role in this Procedure")	CODE	1	U		ImageAnnotationCollection/user/roleInTrial/@value	ST	0..1	BCID 7453 "Performing Roles" Values mapped are amended in CP 1734. AIM does not define a value set for the roles, so no standard mapping to the DICOM codes is defined.
(126000, DCM, "Imaging Measurement Report") > (121011, DCM, "Person Observer's Role in this Procedure") > (128775, DCM, "Identifier within Person Observer's Role")	TEXT	1	U		ImageAnnotationCollection/user/numberWithinRoleOfClinicalTrial/@value	INT	0..1	DICOM allows for alphanumeric, whereas AIM is INT only.

TID 1600 Mapping of Image Library

This section describes the mapping of PS3.16 TID 1600 "Image Library".

Table TID 1600. Mapping of Image Library

DICOM SR Path	DICOM VT	DICOM VM	DICOM Usage Type	Generated Value	AIM Element or Attribute	AIM Data Type	AIM Multiplicity	Comment
(126000, DCM, "Imaging Measurement Report") > (111028, DCM, "Image Library")	CONTAINER	1	M					
(126000, DCM, "Imaging Measurement Report") > (111028, DCM, "Image Library") > (126200, DCM, "Image Library Group")	CONTAINER	1-n	U					
(126000, DCM, "Imaging Measurement Report") > (111028, DCM, "Image Library") > (126200, DCM, "Image Library Group") >	INCLUDE	1	U		TID 1602 "Mapping of Image Library Entry Descriptors"			
(126000, DCM, "Imaging Measurement Report") > (111028, DCM, "Image Library") > (126200, DCM, "Image Library Group") >	INCLUDE	1-n	U		TID 1601 "Mapping of Image Library Entry"			

TID 1601 Mapping of Image Library Entry

This section describes the mapping of PS3.16 TID 1601 "Image Library Entry".

Table TID 1601. Mapping of Image Library Entry

DICOM SR Path	DICOM VT	DICOM VM	DICOM Usage Type	Generated Value	AIM Element or Attribute	AIM Data Type	AIM Multiplicity	Comment
(126000, DCM, "Imaging Measurement Report") > (111028, DCM, "Image Library") > (126200, DCM, "Image Library Group") > IMAGE	IMAGE	1	M		/ImageAnnotationCollection/imageAnnotations/ImageAnnotation/imageReferenceEntityCollection/ImageReferenceEntity/imageStudy/imageSeries/imageCollection/Image/sopInstanceUid/@root, sopClassUid/@root	II, II	1, 1	
(126000, DCM, "Imaging Measurement Report") > (111028, DCM, "Image Library") > (126200, DCM, "Image Library Group") > IMAGE >	INCLUDE	1	U		TID 1602 "Mapping of Image Library Entry Descriptors"			

TID 1602 Mapping of Image Library Entry Descriptors

This section describes the mapping of PS3.16 TID 1602 "Image Library Entry Descriptors".

Table TID 1602. Mapping of Image Library Entry Descriptors

DICOM SR Path	DICOM VT	DICOM VM	DICOM Usage Type	Generated Value	AIM Element or Attribute	AIM Data Type	AIM Multiplicity	Comment
(126000, DCM, "Imaging Measurement Report") > (111028, DCM, "Image Library") > (126200, DCM, "Image Library Group") > (121139, DCM, "Modality")	CODE	1	U		/ImageAnnotationCollection/imageAnnotations/ImageAnnotation/imageReferenceEntityCollection/ImageReferenceEntity/imageStudy/imageSeries/modality/@code	CD	1..1	AIM does not formally define a value set but common usage is the set of code strings defined for the image Modality Attribute, and these have a 1:1 correspondence with the code values of CID 29 "Acquisition Modality"
(126000, DCM, "Imaging Measurement Report") > (111028, DCM, "Image Library") > (126200, DCM, "Image Library Group") > (123014, DCM, "Target Region")	CODE	1	U					Not used in AIM; discarded if present in DICOM SR.
(126000, DCM, "Imaging Measurement Report") > (111028, DCM, "Image Library") > (126200, DCM, "Image Library Group") > (111027, DCM, "Image Laterality")	CODE	1	U					Not used in AIM; discarded if present in DICOM SR.
(126000, DCM, "Imaging Measurement Report") > (111028, DCM, "Image Library") > (126200, DCM, "Image Library Group") > (111060, DCM, "Study Date")	DATE	1	U		/ImageAnnotationCollection/imageAnnotations/ImageAnnotation/imageReferenceEntityCollection/ImageReferenceEntity/imageStudy/startDate/@value	TS	1..1	

DICOM SR Path	DICOM VT	DICOM VM	DICOM Usage Type	Generated Value	AIM Element or Attribute	AIM Data Type	AIM Multiplicity	Comment
(126000, DCM, "Imaging Measurement Report") > (111028, DCM, "Image Library") > (126200, DCM, "Image Library Group") > (111061, DCM, "Study Time")	TIME	1	U		/ImageAnnotationCollection/imageAnnotations/ImageAnnotation/imageReferenceEntityCollection/ImageReferenceEntity/imageStudy/startTime/@value	TS	1..1	
(126000, DCM, "Imaging Measurement Report") > (111028, DCM, "Image Library") > (126200, DCM, "Image Library Group") > (111018, DCM, "Content Date")	DATE	1	U					Not used in AIM; discarded if present in DICOM SR.
(126000, DCM, "Imaging Measurement Report") > (111028, DCM, "Image Library") > (126200, DCM, "Image Library Group") > (111019, DCM, "Content Time")	TIME	1	U					Not used in AIM; discarded if present in DICOM SR.
(126000, DCM, "Imaging Measurement Report") > (111028, DCM, "Image Library") > (126200, DCM, "Image Library Group") > (126201, DCM, "Acquisition Date")	DATE	1	U					Not used in AIM; discarded if present in DICOM SR.
(126000, DCM, "Imaging Measurement Report") > (111028, DCM, "Image Library") > (126200, DCM, "Image Library Group") > (126202, DCM, "Acquisition Time")	TIME	1	U					Not used in AIM; discarded if present in DICOM SR.

DICOM SR Path	DICOM VT	DICOM VM	DICOM Usage Type	Generated Value	AIM Element or Attribute	AIM Data Type	AIM Multiplicity	Comment
(126000, DCM, "Imaging Measurement Report") > (111028, DCM, "Image Library") > (126200, DCM, "Image Library Group") > (112227, DCM, "Frame of Reference UID")	UIDREF	1	U					Not used in AIM; discarded if present in DICOM SR.
(126000, DCM, "Imaging Measurement Report") > (111028, DCM, "Image Library") > (126200, DCM, "Image Library Group") > (110910, DCM, "Pixel Data Rows")	NUM	1	U					Not used in AIM; discarded if present in DICOM SR.
(126000, DCM, "Imaging Measurement Report") > (111028, DCM, "Image Library") > (126200, DCM, "Image Library Group") > (110911, DCM, "Pixel Data Columns")	NUM	1	U					Not used in AIM; discarded if present in DICOM SR.
(126000, DCM, "Imaging Measurement Report") > (111028, DCM, "Image Library") > (126200, DCM, "Image Library Group") >	INCLUDE	1	U	TID 1603 "Image Library Entry Descriptors for Projection Radiography"				Not used in AIM; discarded if present in DICOM SR.
(126000, DCM, "Imaging Measurement Report") > (111028, DCM, "Image Library") > (126200, DCM, "Image Library Group") >	INCLUDE	1	U	TID 1604 "Image Library Entry Descriptors for Cross-Sectional Modalities"				Not used in AIM; discarded if present in DICOM SR.

53
54

1
2
3

4
5
6
7
8
9
10
11
12
13
14

15
16
17
18
19
20
21
22
23
24

25
26
27
28
29
30
31
32
33
34
35

36
37
38
39
40
41
42
43

44
45
46
47
48
49
50
51

DICOM SR Path	DICOM VT	DICOM VM	DICOM Usage Type	Generated Value	AIM Element or Attribute	AIM Data Type	AIM Multiplicity	Comment
(126000, DCM, "Imaging Measurement Report") > (111028, DCM, "Image Library") > (126200, DCM, "Image Library Group") >	INCLUDE	1	U	TID 1605 "Image Library Entry Descriptors for CT"				Not used in AIM; discarded if present in DICOM SR.
(126000, DCM, "Imaging Measurement Report") > (111028, DCM, "Image Library") > (126200, DCM, "Image Library Group") >	INCLUDE	1	U	TID 1606 "Image Library Entry Descriptors for MR"				Not used in AIM; discarded if present in DICOM SR.
(126000, DCM, "Imaging Measurement Report") > (111028, DCM, "Image Library") > (126200, DCM, "Image Library Group") >	INCLUDE	1	U	TID 1607 "Image Library Entry Descriptors for PET"				Not used in AIM; discarded if present in DICOM SR.

A.7 Sample Documents

This section describes a sample AIM v4 instance and the same content transformed into a DICOM SR TID 1500 instance.

A.7.1 Source AIM v4 Instance

```

<?xml version="1.0" encoding="UTF-8"?>
<ImageAnnotationCollection xmlns="gme://caCORE.caCORE/4.4/edu.northwestern.radiology.AIM" xmlns:rdf="http://www.w3.org/1999/02/22-
  <uniqueIdentifier root="2.25.224793923339609181243139195858254344686"/>
  <dateTime value="20170201180043"/>
  <user>
    <name value="Doe^Jane"/>
    <loginName value="jdoe"/>
    <roleInTrial/>
  </user>
  <equipment>
    <manufacturerName value="Acme Medical Systems"/>
    <manufacturerModelName value=""/>
    <softwareVersion value="36.00"/>
  </equipment>
  <person>
    <name value="CM-1-111-000000"/>
    <id value="293761767066931586407385203810190772174"/>
    <birthDate value="19600101000000"/>
    <sex value="M"/>
    <ethnicGroup/>
  </person>
  <imageAnnotations>
    <ImageAnnotation>
      <uniqueIdentifier root="2.25.56002466128627498886935079903172938041"/>

```

```
1 <typeCode code="M-01100" codeSystemName="SRT">
2   <iso:displayName xmlns:iso="uri:iso.org:21090" value="Lesion"/>
3 </typeCode>
4 <dateTime value="20170201180043"/>
5 <name value="Lesion1"/>
6 <comment value="PT / WB NAC P600 / 0"/>
7 <calculationEntityCollection>
8   <CalculationEntity>
9     <uniqueIdentifier root="0"/>
10    <typeCode code="126401" codeSystemName="DCM">
11      <iso:displayName xmlns:iso="uri:iso.org:21090" value="SUVbw"/>
12    </typeCode>
13    <typeCode code="R-404FB" codeSystemName="SRT">
14      <iso:displayName xmlns:iso="uri:iso.org:21090" value="Minimum"/>
15    </typeCode>
16    <description value="SUVbw Minimum"/>
17    <mathML/>
18    <calculationResultCollection>
19      <CalculationResult type="Scalar" xsi:type="CompactCalculationResult">
20        <unitOfMeasure value="g/ml{SUVbw}"/>
21        <dataType code="C48870" codeSystemName="NCI">
22          <iso:displayName xmlns:iso="uri:iso.org:21090" value="Double"/>
23        </dataType>
24        <dimensionCollection>
25          <Dimension>
26            <index value="0"/>
27            <size value="1"/>
28            <label value="Minimum"/>
29          </Dimension>
30        </dimensionCollection>
31        <value value="1.98024"/>
32      </CalculationResult>
33    </calculationResultCollection>
34    <algorithm>
35      <name value="Descriptive Statistics Calculator"/>
36      <type code="RID12780" codeSystemName="RadLex" codeSystemVersion="3.2">
37        <iso:displayName xmlns:iso="uri:iso.org:21090" value="Calculation"/>
38      </type>
39      <version value="1.0"/>
40    </algorithm>
41  </CalculationEntity>
42  <CalculationEntity>
43    <uniqueIdentifier root="0"/>
44    <typeCode code="126401" codeSystemName="DCM">
45      <iso:displayName xmlns:iso="uri:iso.org:21090" value="SUVbw"/>
46    </typeCode>
47    <typeCode code="G-A437" codeSystemName="SRT">
48      <iso:displayName xmlns:iso="uri:iso.org:21090" value="Maximum"/>
49    </typeCode>
50    <description value="SUVbw Maximum"/>
51    <mathML/>
52    <calculationResultCollection>
53      <CalculationResult type="Scalar" xsi:type="CompactCalculationResult">
54        <unitOfMeasure value="g/ml{SUVbw}"/>
55        <dataType code="C48870" codeSystemName="NCI">
56          <iso:displayName xmlns:iso="uri:iso.org:21090" value="Double"/>
57        </dataType>
58        <dimensionCollection>
59          <Dimension>
60            <index value="0"/>
```

```
1         <size value="1"/>
2         <label value="Maximum"/>
3     </Dimension>
4 </dimensionCollection>
5     <value value="5.68816"/>
6 </CalculationResult>
7 </calculationResultCollection>
8 <algorithm>
9     <name value="Descriptive Statistics Calculator"/>
10    <type code="RID12780" codeSystemName="RadLex" codeSystemVersion="3.2">
11        <iso:displayName xmlns:iso="uri:iso.org:21090" value="Calculation"/>
12    </type>
13    <version value="1.0"/>
14 </algorithm>
15 </CalculationEntity>
16 <CalculationEntity>
17     <uniqueIdentifier root="0"/>
18     <typeCode code="126401" codeSystemName="DCM">
19         <iso:displayName xmlns:iso="uri:iso.org:21090" value="SUVbw"/>
20     </typeCode>
21     <typeCode code="R-00317" codeSystemName="SRT">
22         <iso:displayName xmlns:iso="uri:iso.org:21090" value="Mean"/>
23     </typeCode>
24     <description value="SUVbw Mean"/>
25     <mathML/>
26     <calculationResultCollection>
27         <CalculationResult type="Scalar" xsi:type="CompactCalculationResult">
28             <unitOfMeasure value="g/ml{SUVbw}"/>
29             <dataType code="C48870" codeSystemName="NCI">
30                 <iso:displayName xmlns:iso="uri:iso.org:21090" value="Double"/>
31             </dataType>
32             <dimensionCollection>
33                 <Dimension>
34                     <index value="0"/>
35                     <size value="1"/>
36                     <label value="Mean"/>
37                 </Dimension>
38             </dimensionCollection>
39             <value value="2.329186593407"/>
40         </CalculationResult>
41     </calculationResultCollection>
42 </algorithm>
43     <name value="Descriptive Statistics Calculator"/>
44     <type code="RID12780" codeSystemName="RadLex" codeSystemVersion="3.2">
45         <iso:displayName xmlns:iso="uri:iso.org:21090" value="Calculation"/>
46     </type>
47     <version value="1.0"/>
48 </algorithm>
49 </CalculationEntity>
50 <CalculationEntity>
51     <uniqueIdentifier root="0"/>
52     <typeCode code="126401" codeSystemName="DCM">
53         <iso:displayName xmlns:iso="uri:iso.org:21090" value="SUVbw"/>
54     </typeCode>
55     <typeCode code="R-10047" codeSystemName="SRT">
56         <iso:displayName xmlns:iso="uri:iso.org:21090" value="Standard Deviation"/>
57     </typeCode>
58     <description value="SUVbw Standard Deviation"/>
59     <mathML/>
60     <calculationResultCollection>
```

```
1      <CalculationResult type="Scalar" xsi:type="CompactCalculationResult">
2        <unitOfMeasure value="g/ml{SUVbw}"/>
3        <dataType code="C48870" codeSystemName="NCI">
4          <iso:displayName xmlns:iso="uri:iso.org:21090" value="Double"/>
5        </dataType>
6        <dimensionCollection>
7          <Dimension>
8            <index value="0"/>
9            <size value="1"/>
10           <label value="Standard Deviation"/>
11         </Dimension>
12       </dimensionCollection>
13       <value value="1.8828952323684"/>
14     </CalculationResult>
15   </calculationResultCollection>
16   <algorithm>
17     <name value="Descriptive Statistics Calculator"/>
18     <type code="RID12780" codeSystemName="RadLex" codeSystemVersion="3.2">
19       <iso:displayName xmlns:iso="uri:iso.org:21090" value="Calculation"/>
20     </type>
21     <version value="1.0"/>
22   </algorithm>
23 </CalculationEntity>
24 </calculationEntityCollection>
25 <segmentationEntityCollection>
26   <SegmentationEntity xsi:type="DicomSegmentationEntity">
27     <uniqueIdentifier root="2.25.318310842062810077214341266367812728264"/>
28     <sopInstanceUid root="2.25.134884066033959077306435705240550195701"/>
29     <sopClassUid root="1.2.840.10008.5.1.4.1.1.66.4"/>
30     <referencedSopInstanceUid root="2.25.319214308104243787945491694789635628411"/>
31     <segmentNumber value="1"/>
32   </SegmentationEntity>
33 </segmentationEntityCollection>
34 <imageReferenceEntityCollection>
35   <ImageReferenceEntity xsi:type="DicomImageReferenceEntity">
36     <uniqueIdentifier root="2.25.239108061065263370785162033783811931375"/>
37     <imageStudy>
38       <instanceUid root="2.25.52186905385055707830834793159643714079"/>
39       <startDate value="20170113"/>
40       <startTime value="070844"/>
41       <imageSeries>
42         <instanceUid root="2.25.263500776851326986665835510707132143772"/>
43         <modality code="PT" codeSystemName="DCM" codeSystemVersion="20121129">
44           <iso:displayName xmlns:iso="uri:iso.org:21090" value="Positron emission tomography"/>
45         </modality>
46         <imageCollection>
47           <Image>
48             <sopClassUid root="1.2.840.10008.5.1.4.1.1.128"/>
49             <sopInstanceUid root="2.25.319214308104243787945491694789635628411"/>
50           </Image>
51         </imageCollection>
52       </imageSeries>
53     </imageStudy>
54   </ImageReferenceEntity>
55 </imageReferenceEntityCollection>
56 </ImageAnnotation>
57 </imageAnnotations>
58 </ImageAnnotationCollection>
```

A.7.2 Target DICOM SR "Measurement Report" (TID 1500)

A compact representation of the semantic content of the transformed DICOM SR tree is shown here:

```

1: : CONTAINER: (126000,DCM,"Imaging Measurement Report") [SEPARATE] (DCMR,1500)
>1.1: HAS CONCEPT MOD: CODE: (121049,DCM,"Language of Content Item and Descendants") = (eng,RFC5646,"English")
>>1.1.1: HAS CONCEPT MOD: CODE: (121046,DCM,"Country of Language") = (US,ISO3166_1,"United States")
>1.2: HAS OBS CONTEXT: PNAME: (121008,DCM,"Person Observer Name") = "Doe^Jane"
>1.3: HAS OBS CONTEXT: TEXT: (128774,DCM,"Person Observer's Login Name") = "jdoe"
>1.4: HAS CONCEPT MOD: CODE: (121058,DCM,"Procedure reported") = (44139-4,LN,"PET whole body")
>1.5: CONTAINS: CONTAINER: (111028,DCM,"Image Library") [SEPARATE]
>>1.5.1: CONTAINS: CONTAINER: (126200,DCM,"Image Library Group") [SEPARATE]
>>>1.5.1.1: CONTAINS: IMAGE: = (1.2.840.10008.5.1.4.1.1.128,2.25.319214308104243787945491694789635628411)
>>>1.5.1.2: HAS ACQ CONTEXT: CODE: (121139,DCM,"Modality") = (PT,DCM,"Positron emission tomography")
>>>1.5.1.3: HAS ACQ CONTEXT: DATE: (111060,DCM,"Study Date") = "20170113"
>>>1.5.1.4: HAS ACQ CONTEXT: TIME: (111061,DCM,"Study Time") = "070844"
>1.6: CONTAINS: CONTAINER: (126010,DCM,"Imaging Measurements") [SEPARATE]
>>1.6.1: CONTAINS: CONTAINER: (125007,DCM,"Measurement Group") [SEPARATE]
>>>1.6.1.1: HAS OBS CONTEXT: TEXT: (112039,DCM,"Tracking Identifier") = "Lesion1"
>>>1.6.1.2: HAS OBS CONTEXT: UIDREF: (112040,DCM,"Tracking Unique Identifier") = "2.25.5600246612862749888693507990317293"
>>>1.6.1.3: CONTAINS: CODE: (121071,DCM,"Finding") = (M-01100,SRT,"Lesion")
>>>1.6.1.4: CONTAINS: IMAGE: (121191,DCM,"Referenced Segment") = (1.2.840.10008.5.1.4.1.1.66.4,2.25.1348840660339590773064)
>>>1.6.1.5: CONTAINS: NUM: (126401,DCM,"SUVbw") = 1.98024 (g/ml{SUVbw},UCUM,"Standardized Uptake Value body weight")
>>>>1.6.1.5.1: HAS CONCEPT MOD: CODE: (121401,DCM,"Derivation") = (R-404FB,SRT,"Minimum")
>>>>1.6.1.5.2: HAS CONCEPT MOD: TEXT: (111001,DCM,"Algorithm Name") = "Descriptive Statistics Calculator"
>>>>1.6.1.5.3: HAS CONCEPT MOD: TEXT: (111003,DCM,"Algorithm Version") = "1.0"
>>>>1.6.1.6: CONTAINS: NUM: (126401,DCM,"SUVbw") = 5.68816 (g/ml{SUVbw},UCUM,"Standardized Uptake Value body weight")
>>>>1.6.1.6.1: HAS CONCEPT MOD: CODE: (121401,DCM,"Derivation") = (G-A437,SRT,"Maximum")
>>>>1.6.1.6.2: HAS CONCEPT MOD: TEXT: (111001,DCM,"Algorithm Name") = "Descriptive Statistics Calculator"
>>>>1.6.1.6.3: HAS CONCEPT MOD: TEXT: (111003,DCM,"Algorithm Version") = "1.0"
>>>>1.6.1.7: CONTAINS: NUM: (126401,DCM,"SUVbw") = 2.329186593407 (g/ml{SUVbw},UCUM,"Standardized Uptake Value body weight")
>>>>1.6.1.7.1: HAS CONCEPT MOD: CODE: (121401,DCM,"Derivation") = (R-00317,SRT,"Mean")
>>>>1.6.1.7.2: HAS CONCEPT MOD: TEXT: (111001,DCM,"Algorithm Name") = "Descriptive Statistics Calculator"
>>>>1.6.1.7.3: HAS CONCEPT MOD: TEXT: (111003,DCM,"Algorithm Version") = "1.0"
>>>>1.6.1.8: CONTAINS: NUM: (126401,DCM,"SUVbw") = 1.8828952323684 (g/ml{SUVbw},UCUM,"Standardized Uptake Value body weight")
>>>>1.6.1.8.1: HAS CONCEPT MOD: CODE: (121401,DCM,"Derivation") = (R-10047,SRT,"Standard Deviation")
>>>>1.6.1.8.2: HAS CONCEPT MOD: TEXT: (111001,DCM,"Algorithm Name") = "Descriptive Statistics Calculator"
>>>>1.6.1.8.3: HAS CONCEPT MOD: TEXT: (111003,DCM,"Algorithm Version") = "1.0"

```

The AIM sample transformed into SR illustrated at the Attribute encoding level shown in Table A.7.2-1 includes information on the SR document body tree depth (column 1: SR Tree Depth), nesting level for nested artifacts such as sequences and sequence items (column 2: Nesting), DICOM attribute names (column 3: Attribute), DICOM tag (column 4: Tag), the DICOM attribute value representation (Column 5: VR as specified in PS3.5), the hexadecimal value of value length (column 6: VL (hex)) and the sample document attribute values (column 7: Value).

Table A.7.2-1. Transformed SR document encoding at the Attribute level

SR Tree Depth	Nesting	Attribute	Tag	VR	VL (hex)	Value
		File Meta Information Group Length	(0002,0000)	UL	0004	0x000000ba
		File Meta Information Version	(0002,0001)	OB	0002	0x00,0x01
		Media Storage SOP Class UID	(0002,0002)	UI	001e	1.2.840.10008.5.1.4.1.1.88.22

SR Tree Depth	Nesting	Attribute	Tag	VR	VL (hex)	Value
		Media Storage SOP Instance UID	(0002,0003)	UI	002c	2.25.224793923339609181243139195858254344686
		Transfer Syntax UID	(0002,0010)	UI	0014	1.2.840.10008.1.2.1
		Implementation Class UID	(0002,0012)	UI	0016	1.3.6.1.4.1.5962.99.2
		Implementation Version Name	(0002,0013)	SH	0010	PIXELMEDJAVA001
		SOP Class UID	(0008,0016)	UI	001e	1.2.840.10008.5.1.4.1.1.88.22
		SOP Instance UID	(0008,0018)	UI	002c	2.25.224793923339609181243139195858254344686
		Study Date	(0008,0020)	DA	0008	20170113
		Content Date	(0008,0023)	DA	0008	20170201
		Study Time	(0008,0030)	TM	0006	070844
		Content Time	(0008,0033)	TM	0006	180043
		Accession Number	(0008,0050)	SH	0000	
		Modality	(0008,0060)	CS	0002	SR
		Manufacturer	(0008,0070)	LO	0000	
		Referring Physician's Name	(0008,0090)	PN	0000	
		Manufacturer's Model Name	(0008,1090)	LO	0000	
		Referenced Performed Procedure Step Sequence	(0008,1111)	SQ	ffffff	
	%endseq					
		Patient's Name	(0010,0010)	PN	0010	CM-1-111-000000
		Patient ID	(0010,0020)	LO	0028	293761767066931586407385203810190772174
		Patient's Birth Date	(0010,0030)	DA	0008	19601000
		Patient's Sex	(0010,0040)	CS	0002	M
		Ethnic Group	(0010,2160)	SH	0000	
		Software Version(s)	(0018,1020)	LO	0006	36.00
		Study Instance UID	(0020,000d)	UI	002c	2.25.52186905385055707830834793159643714079
		Series Instance UID	(0020,000e)	UI	002c	1.3.6.1.4.1.5962.1.3.0.0.1498908445.38939.0
		Study ID	(0020,0010)	SH	0000	
		Series Number	(0020,0011)	IS	0004	7291
		Instance Number	(0020,0013)	IS	0002	1
1		Value Type	(0040,a040)	CS	000a	CONTAINER

SR Tree Depth	Nesting	Attribute	Tag	VR	VL (hex)	Value
1		Concept Name Code Sequence	(0040,a043)	SQ	ffffff	
	%item					
	>	Code Value	(0008,0100)	SH	0006	126000
	>	Coding Scheme Designator	(0008,0102)	SH	0004	DCM
	>	Code Meaning	(0008,0104)	LO	001a	Imaging Measurement Report
	%enditem					
	%endseq					
1		Continuity Of Content	(0040,a050)	CS	0008	SEPARATE
		Performed Procedure Code Sequence	(0040,a372)	SQ	ffffff	
	%endseq					
		Current Requested Procedure Evidence Sequence	(0040,a375)	SQ	ffffff	
	%item					
	>	Referenced Series Sequence	(0008,1115)	SQ	ffffff	
	%item					
	>>	Referenced SOP Sequence	(0008,1199)	SQ	ffffff	
	%item					
	>>>	Referenced SOP Class UID	(0008,1150)	UI	001c	1.2.840.10008.5.1.4.1.1.128
	>>>	Referenced SOP Instance UID	(0008,1155)	UI	002c	2.25.319214308104243787945491694789635628411
	%enditem					
	%endseq					
	>>	Series Instance UID	(0020,000e)	UI	002c	2.25.263500776851326986665835510707132143772
	%enditem					
	%endseq					
	>	Study Instance UID	(0020,000d)	UI	002c	2.25.52186905385055707830834793159643714079
	%enditem					
	%endseq					
		Completion Flag	(0040,a491)	CS	0008	COMPLETE
		Verification Flag	(0040,a493)	CS	000a	UNVERIFIED
		Content Template Sequence	(0040,a504)	SQ	ffffff	

SR Tree Depth	Nesting	Attribute	Tag	VR	VL (hex)	Value
	%item					
	>	Mapping Resource	(0008,0105)	CS	0004	DCMR
	>	Template Identifier	(0040,db00)	CS	0004	1500
	%enditem					
	%endseq					
1		Content Sequence	(0040,a730)	SQ	fffffff	
	%item					
1.1	>	Relationship Type	(0040,a010)	CS	0010	HAS CONCEPT MOD
1.1	>	Value Type	(0040,a040)	CS	0004	CODE
1.1	>	Concept Name Code Sequence	(0040,a043)	SQ	fffffff	
	%item					
1.1	>>	Code Value	(0008,0100)	SH	0006	121049
1.1	>>	Coding Scheme Designator	(0008,0102)	SH	0004	DCM
1.1	>>	Code Meaning	(0008,0104)	LO	0028	Language of Content Item and Descendants
	%enditem					
	%endseq					
1.1	>	Concept Code Sequence	(0040,a168)	SQ	fffffff	
	%item					
1.1	>>	Code Value	(0008,0100)	SH	0004	eng
1.1	>>	Coding Scheme Designator	(0008,0102)	SH	0008	RFC5646
1.1	>>	Code Meaning	(0008,0104)	LO	0008	English
	%enditem					
	%endseq					
1.1	>	Content Sequence	(0040,a730)	SQ	fffffff	
	%item					
1.1.1	>>	Relationship Type	(0040,a010)	CS	0010	HAS CONCEPT MOD
1.1.1	>>	Value Type	(0040,a040)	CS	0004	CODE
1.1.1	>>	Concept Name Code Sequence	(0040,a043)	SQ	fffffff	
	%item					
1.1.1	>>>	Code Value	(0008,0100)	SH	0006	121046
1.1.1	>>>	Coding Scheme Designator	(0008,0102)	SH	0004	DCM
1.1.1	>>>	Code Meaning	(0008,0104)	LO	0014	Country of Language
	%enditem					
	%endseq					

SR Tree Depth	Nesting	Attribute	Tag	VR	VL (hex)	Value
1.1.1	>>	Concept Code Sequence	(0040,a168)	SQ	ffffff	
	%item					
1.1.1	>>>	Code Value	(0008,0100)	SH	0002	US
1.1.1	>>>	Coding Scheme Designator	(0008,0102)	SH	000a	ISO3166_1
1.1.1	>>>	Code Meaning	(0008,0104)	LO	000e	United States
	%enditem					
	%endseq					
	%enditem					
	%endseq					
	%enditem					
	%item					
1.2	>	Relationship Type	(0040,a010)	CS	0010	HAS OBS CONTEXT
1.2	>	Value Type	(0040,a040)	CS	0006	PNAME
1.2	>	Concept Name Code Sequence	(0040,a043)	SQ	ffffff	
	%item					
1.2	>>	Code Value	(0008,0100)	SH	0006	121008
1.2	>>	Coding Scheme Designator	(0008,0102)	SH	0004	DCM
1.2	>>	Code Meaning	(0008,0104)	LO	0014	Person Observer Name
	%enditem					
	%endseq					
1.2	>	Person Name	(0040,a123)	PN	0008	Doe^Jane
	%enditem					
	%item					
1.3	>	Relationship Type	(0040,a010)	CS	0010	HAS OBS CONTEXT
1.3	>	Value Type	(0040,a040)	CS	0004	TEXT
1.3	>	Concept Name Code Sequence	(0040,a043)	SQ	ffffff	
	%item					
1.3	>>	Code Value	(0008,0100)	SH	0006	128774
1.3	>>	Coding Scheme Designator	(0008,0102)	SH	0004	DCM
1.3	>>	Code Meaning	(0008,0104)	LO	001c	Person Observer's Login Name
	%enditem					
	%endseq					
1.3	>	Text Value	(0040,a160)	UT	0004	jdoe
	%enditem					
	%item					
1.4	>	Relationship Type	(0040,a010)	CS	0010	HAS CONCEPT MOD
1.4	>	Value Type	(0040,a040)	CS	0004	CODE

SR Tree Depth	Nesting	Attribute	Tag	VR	VL (hex)	Value
1.4	>	Concept Name Code Sequence	(0040,a043)	SQ	ffffff	
	%item					
1.4	>>	Code Value	(0008,0100)	SH	0006	121058
1.4	>>	Coding Scheme Designator	(0008,0102)	SH	0004	DCM
1.4	>>	Code Meaning	(0008,0104)	LO	0012	Procedure reported
	%enditem					
	%endseq					
1.4	>	Concept Code Sequence	(0040,a168)	SQ	ffffff	
	%item					
1.4	>>	Code Value	(0008,0100)	SH	0008	44139-4
1.4	>>	Coding Scheme Designator	(0008,0102)	SH	0002	LN
1.4	>>	Code Meaning	(0008,0104)	LO	000e	PET whole body
	%enditem					
	%endseq					
	%enditem					
	%item					
1.5	>	Relationship Type	(0040,a010)	CS	0008	CONTAINS
1.5	>	Value Type	(0040,a040)	CS	000a	CONTAINER
1.5	>	Concept Name Code Sequence	(0040,a043)	SQ	ffffff	
	%item					
1.5	>>	Code Value	(0008,0100)	SH	0006	111028
1.5	>>	Coding Scheme Designator	(0008,0102)	SH	0004	DCM
1.5	>>	Code Meaning	(0008,0104)	LO	000e	Image Library
	%enditem					
	%endseq					
1.5	>	Continuity Of Content	(0040,a050)	CS	0008	SEPARATE
1.5	>	Content Sequence	(0040,a730)	SQ	ffffff	
	%item					
1.5.1	>>	Relationship Type	(0040,a010)	CS	0008	CONTAINS
1.5.1	>>	Value Type	(0040,a040)	CS	000a	CONTAINER
1.5.1	>>	Concept Name Code Sequence	(0040,a043)	SQ	ffffff	
	%item					
1.5.1	>>>	Code Value	(0008,0100)	SH	0006	126200
1.5.1	>>>	Coding Scheme Designator	(0008,0102)	SH	0004	DCM

SR Tree Depth	Nesting	Attribute	Tag	VR	VL (hex)	Value
1.5.1	>>>	Code Meaning	(0008,0104)	LO	0014	Image Library Group
	%enditem					
	%endseq					
1.5.1	>>	Continuity Of Content	(0040,a050)	CS	0008	SEPARATE
1.5.1	>>	Content Sequence	(0040,a730)	SQ	fffffff	
	%item					
1.5.1.1	>>>	Referenced SOP Sequence	(0008,1199)	SQ	fffffff	
	%item					
1.5.1.1	>>>>	Referenced SOP Class UID	(0008,1150)	UI	001c	1.2.840.10008.5.1.4.1.1.128
1.5.1.1	>>>>	Referenced SOP Instance UID	(0008,1155)	UI	002c	2.25.319214308104243787945491694789635628411
	%enditem					
	%endseq					
1.5.1.1	>>>	Relationship Type	(0040,a010)	CS	0008	CONTAINS
1.5.1.1	>>>	Value Type	(0040,a040)	CS	0006	IMAGE
	%enditem					
	%item					
1.5.1.2	>>>	Relationship Type	(0040,a010)	CS	0010	HAS ACQ CONTEXT
1.5.1.2	>>>	Value Type	(0040,a040)	CS	0004	CODE
1.5.1.2	>>>	Concept Name Code Sequence	(0040,a043)	SQ	fffffff	
	%item					
1.5.1.2	>>>>	Code Value	(0008,0100)	SH	0006	121139
1.5.1.2	>>>>	Coding Scheme Designator	(0008,0102)	SH	0004	DCM
1.5.1.2	>>>>	Code Meaning	(0008,0104)	LO	0008	Modality
	%enditem					
	%endseq					
1.5.1.2	>>>	Concept Code Sequence	(0040,a168)	SQ	fffffff	
	%item					
1.5.1.2	>>>>	Code Value	(0008,0100)	SH	0002	PT
1.5.1.2	>>>>	Coding Scheme Designator	(0008,0102)	SH	0004	DCM
1.5.1.2	>>>>	Code Meaning	(0008,0104)	LO	001c	Positron emission tomography
	%enditem					
	%endseq					
	%enditem					
	%item					

SR Tree Depth	Nesting	Attribute	Tag	VR	VL (hex)	Value
1.5.1.3	>>>	Relationship Type	(0040,a010)	CS	0010	HAS ACQ CONTEXT
1.5.1.3	>>>	Value Type	(0040,a040)	CS	0004	DATE
1.5.1.3	>>>	Concept Name Code Sequence	(0040,a043)	SQ	ffffff	
	%item					
1.5.1.3	>>>>	Code Value	(0008,0100)	SH	0006	111060
1.5.1.3	>>>>	Coding Scheme Designator	(0008,0102)	SH	0004	DCM
1.5.1.3	>>>>	Code Meaning	(0008,0104)	LO	000a	Study Date
	%enditem					
	%endseq					
1.5.1.3	>>>	Date	(0040,a121)	DA	0008	20170113
	%enditem					
	%item					
1.5.1.4	>>>	Relationship Type	(0040,a010)	CS	0010	HAS ACQ CONTEXT
1.5.1.4	>>>	Value Type	(0040,a040)	CS	0004	TIME
1.5.1.4	>>>	Concept Name Code Sequence	(0040,a043)	SQ	ffffff	
	%item					
1.5.1.4	>>>>	Code Value	(0008,0100)	SH	0006	111061
1.5.1.4	>>>>	Coding Scheme Designator	(0008,0102)	SH	0004	DCM
1.5.1.4	>>>>	Code Meaning	(0008,0104)	LO	000a	Study Time
	%enditem					
	%endseq					
1.5.1.4	>>>	Time	(0040,a122)	TM	0006	070844
	%enditem					
	%endseq					
	%enditem					
	%endseq					
	%enditem					
	%item					
1.6	>	Relationship Type	(0040,a010)	CS	0008	CONTAINS
1.6	>	Value Type	(0040,a040)	CS	000a	CONTAINER
1.6	>	Concept Name Code Sequence	(0040,a043)	SQ	ffffff	
	%item					
1.6	>>	Code Value	(0008,0100)	SH	0006	126010
1.6	>>	Coding Scheme Designator	(0008,0102)	SH	0004	DCM
1.6	>>	Code Meaning	(0008,0104)	LO	0014	Imaging Measurements
	%enditem					
	%endseq					

SR Tree Depth	Nesting	Attribute	Tag	VR	VL (hex)	Value
1.6	>	Continuity Of Content	(0040,a050)	CS	0008	SEPARATE
1.6	>	Content Sequence	(0040,a730)	SQ	fffffff	
	%item					
1.6.1	>>	Relationship Type	(0040,a010)	CS	0008	CONTAINS
1.6.1	>>	Value Type	(0040,a040)	CS	000a	CONTAINER
1.6.1	>>	Concept Name Code Sequence	(0040,a043)	SQ	fffffff	
	%item					
1.6.1	>>>	Code Value	(0008,0100)	SH	0006	125007
1.6.1	>>>	Coding Scheme Designator	(0008,0102)	SH	0004	DCM
1.6.1	>>>	Code Meaning	(0008,0104)	LO	0012	Measurement Group
	%enditem					
	%endseq					
1.6.1	>>	Continuity Of Content	(0040,a050)	CS	0008	SEPARATE
1.6.1	>>	Content Sequence	(0040,a730)	SQ	fffffff	
	%item					
1.6.1.1	>>>	Relationship Type	(0040,a010)	CS	0010	HAS OBS CONTEXT
1.6.1.1	>>>	Value Type	(0040,a040)	CS	0004	TEXT
1.6.1.1	>>>	Concept Name Code Sequence	(0040,a043)	SQ	fffffff	
	%item					
1.6.1.1	>>>>	Code Value	(0008,0100)	SH	0006	112039
1.6.1.1	>>>>	Coding Scheme Designator	(0008,0102)	SH	0004	DCM
1.6.1.1	>>>>	Code Meaning	(0008,0104)	LO	0014	Tracking Identifier
	%enditem					
	%endseq					
1.6.1.1	>>>	Text Value	(0040,a160)	UT	0008	Lesion1
	%enditem					
	%item					
1.6.1.2	>>>	Relationship Type	(0040,a010)	CS	0010	HAS OBS CONTEXT
1.6.1.2	>>>	Value Type	(0040,a040)	CS	0006	UIDREF
1.6.1.2	>>>	Concept Name Code Sequence	(0040,a043)	SQ	fffffff	
	%item					
1.6.1.2	>>>>	Code Value	(0008,0100)	SH	0006	112040
1.6.1.2	>>>>	Coding Scheme Designator	(0008,0102)	SH	0004	DCM
1.6.1.2	>>>>	Code Meaning	(0008,0104)	LO	001a	Tracking Unique Identifier

SR Tree Depth	Nesting	Attribute	Tag	VR	VL (hex)	Value
	%enditem					
	%endseq					
1.6.1.2	>>>	UID	(0040,a124)	UI	002c	2.25.56002466128627498886935079903172938041
	%enditem					
	%item					
1.6.1.3	>>>	Relationship Type	(0040,a010)	CS	0008	CONTAINS
1.6.1.3	>>>	Value Type	(0040,a040)	CS	0004	CODE
1.6.1.3	>>>	Concept Name Code Sequence	(0040,a043)	SQ	ffffff	
	%item					
1.6.1.3	>>>>	Code Value	(0008,0100)	SH	0006	121071
1.6.1.3	>>>>	Coding Scheme Designator	(0008,0102)	SH	0004	DCM
1.6.1.3	>>>>	Code Meaning	(0008,0104)	LO	0008	Finding
	%enditem					
	%endseq					
1.6.1.3	>>>	Concept Code Sequence	(0040,a168)	SQ	ffffff	
	%item					
1.6.1.3	>>>>	Code Value	(0008,0100)	SH	0008	M-01100
1.6.1.3	>>>>	Coding Scheme Designator	(0008,0102)	SH	0004	SRT
1.6.1.3	>>>>	Code Meaning	(0008,0104)	LO	0006	Lesion
	%enditem					
	%endseq					
	%enditem					
	%item					
1.6.1.4	>>>	Referenced SOP Sequence	(0008,1199)	SQ	ffffff	
	%item					
1.6.1.4	>>>>	Referenced SOP Class UID	(0008,1150)	UI	001c	1.2.840.10008.5.1.4.1.1.66.4
1.6.1.4	>>>>	Referenced SOP Instance UID	(0008,1155)	UI	002c	2.25.134884066033959077306435705240550195701
1.6.1.4	>>>>	Referenced Segment Number	(0062,000b)	US	0002	0x0001
	%enditem					
	%endseq					
1.6.1.4	>>>	Relationship Type	(0040,a010)	CS	0008	CONTAINS
1.6.1.4	>>>	Value Type	(0040,a040)	CS	0006	IMAGE
1.6.1.4	>>>	Concept Name Code Sequence	(0040,a043)	SQ	ffffff	
	%item					

SR Tree Depth	Nesting	Attribute	Tag	VR	VL (hex)	Value
1.6.1.4	>>>>	Code Value	(0008,0100)	SH	0006	121191
1.6.1.4	>>>>	Coding Scheme Designator	(0008,0102)	SH	0004	DCM
1.6.1.4	>>>>	Code Meaning	(0008,0104)	LO	0012	Referenced Segment
	%enditem					
	%endseq					
	%enditem					
	%item					
1.6.1.5	>>>	Relationship Type	(0040,a010)	CS	0008	CONTAINS
1.6.1.5	>>>	Value Type	(0040,a040)	CS	0004	NUM
1.6.1.5	>>>	Concept Name Code Sequence	(0040,a043)	SQ	ffffff	
	%item					
1.6.1.5	>>>>	Code Value	(0008,0100)	SH	0006	126401
1.6.1.5	>>>>	Coding Scheme Designator	(0008,0102)	SH	0004	DCM
1.6.1.5	>>>>	Code Meaning	(0008,0104)	LO	0006	SUVbw
	%enditem					
	%endseq					
1.6.1.5	>>>	Measured Value Sequence	(0040,a300)	SQ	ffffff	
	%item					
1.6.1.5	>>>>	Measurement Units Code Sequence	(0040,08ea)	SQ	ffffff	
	%item					
1.6.1.5	>>>>>	Code Value	(0008,0100)	SH	000c	g/ml{SUVbw}
1.6.1.5	>>>>>	Coding Scheme Designator	(0008,0102)	SH	0004	UCUM
1.6.1.5	>>>>>	Code Meaning	(0008,0104)	LO	0026	Standardized Uptake Value body weight
	%enditem					
	%endseq					
1.6.1.5	>>>>	Numeric Value	(0040,a30a)	DS	0008	1.98024
	%enditem					
	%endseq					
1.6.1.5	>>>	Content Sequence	(0040,a730)	SQ	ffffff	
	%item					
1.6.1.5.1	>>>>	Relationship Type	(0040,a010)	CS	0010	HAS CONCEPT MOD
1.6.1.5.1	>>>>	Value Type	(0040,a040)	CS	0004	CODE
1.6.1.5.1	>>>>	Concept Name Code Sequence	(0040,a043)	SQ	ffffff	
	%item					

SR Tree Depth	Nesting	Attribute	Tag	VR	VL (hex)	Value
1.6.1.5.1	>>>>	Code Value	(0008,0100)	SH	0006	121401
1.6.1.5.1	>>>>	Coding Scheme Designator	(0008,0102)	SH	0004	DCM
1.6.1.5.1	>>>>	Code Meaning	(0008,0104)	LO	000a	Derivation
	%enditem					
	%endseq					
1.6.1.5.1	>>>>	Concept Code Sequence	(0040,a168)	SQ	fffffff	
	%item					
1.6.1.5.1	>>>>	Code Value	(0008,0100)	SH	0008	R-404FB
1.6.1.5.1	>>>>	Coding Scheme Designator	(0008,0102)	SH	0004	SRT
1.6.1.5.1	>>>>	Code Meaning	(0008,0104)	LO	0008	Minimum
	%enditem					
	%endseq					
	%enditem					
	%item					
1.6.1.5.2	>>>>	Relationship Type	(0040,a010)	CS	0010	HAS CONCEPT MOD
1.6.1.5.2	>>>>	Value Type	(0040,a040)	CS	0004	TEXT
1.6.1.5.2	>>>>	Concept Name Code Sequence	(0040,a043)	SQ	fffffff	
	%item					
1.6.1.5.2	>>>>	Code Value	(0008,0100)	SH	0006	111001
1.6.1.5.2	>>>>	Coding Scheme Designator	(0008,0102)	SH	0004	DCM
1.6.1.5.2	>>>>	Code Meaning	(0008,0104)	LO	000e	Algorithm Name
	%enditem					
	%endseq					
1.6.1.5.2	>>>>	Text Value	(0040,a160)	UT	0022	Descriptive Statistics Calculator
	%enditem					
	%item					
1.6.1.5.3	>>>>	Relationship Type	(0040,a010)	CS	0010	HAS CONCEPT MOD
1.6.1.5.3	>>>>	Value Type	(0040,a040)	CS	0004	TEXT
1.6.1.5.3	>>>>	Concept Name Code Sequence	(0040,a043)	SQ	fffffff	
	%item					
1.6.1.5.3	>>>>	Code Value	(0008,0100)	SH	0006	111003
1.6.1.5.3	>>>>	Coding Scheme Designator	(0008,0102)	SH	0004	DCM
1.6.1.5.3	>>>>	Code Meaning	(0008,0104)	LO	0012	Algorithm Version
	%enditem					
	%endseq					
1.6.1.5.3	>>>>	Text Value	(0040,a160)	UT	0004	1.0

SR Tree Depth	Nesting	Attribute	Tag	VR	VL (hex)	Value
	%enditem					
	%endseq					
	%enditem					
	%item					
1.6.1.6	>>>	Relationship Type	(0040,a010)	CS	0008	CONTAINS
1.6.1.6	>>>	Value Type	(0040,a040)	CS	0004	NUM
1.6.1.6	>>>	Concept Name Code Sequence	(0040,a043)	SQ	ffffff	
	%item					
1.6.1.6	>>>>	Code Value	(0008,0100)	SH	0006	126401
1.6.1.6	>>>>	Coding Scheme Designator	(0008,0102)	SH	0004	DCM
1.6.1.6	>>>>	Code Meaning	(0008,0104)	LO	0006	SUVbw
	%enditem					
	%endseq					
1.6.1.6	>>>	Measured Value Sequence	(0040,a300)	SQ	ffffff	
	%item					
1.6.1.6	>>>>	Measurement Units Code Sequence	(0040,08ea)	SQ	ffffff	
	%item					
1.6.1.6	>>>>>	Code Value	(0008,0100)	SH	000c	g/ml{SUVbw}
1.6.1.6	>>>>>	Coding Scheme Designator	(0008,0102)	SH	0004	UCUM
1.6.1.6	>>>>>	Code Meaning	(0008,0104)	LO	0026	Standardized Uptake Value body weight
	%enditem					
	%endseq					
1.6.1.6	>>>>	Numeric Value	(0040,a30a)	DS	0008	5.68816
	%enditem					
	%endseq					
1.6.1.6	>>>	Content Sequence	(0040,a730)	SQ	ffffff	
	%item					
1.6.1.6.1	>>>>	Relationship Type	(0040,a010)	CS	0010	HAS CONCEPT MOD
1.6.1.6.1	>>>>	Value Type	(0040,a040)	CS	0004	CODE
1.6.1.6.1	>>>>	Concept Name Code Sequence	(0040,a043)	SQ	ffffff	
	%item					
1.6.1.6.1	>>>>>	Code Value	(0008,0100)	SH	0006	121401
1.6.1.6.1	>>>>>	Coding Scheme Designator	(0008,0102)	SH	0004	DCM
1.6.1.6.1	>>>>>	Code Meaning	(0008,0104)	LO	000a	Derivation

SR Tree Depth	Nesting	Attribute	Tag	VR	VL (hex)	Value
	%enditem					
	%endseq					
1.6.1.6.1	>>>>	Concept Code Sequence	(0040,a168)	SQ	ffffff	
	%item					
1.6.1.6.1	>>>>>	Code Value	(0008,0100)	SH	0006	G-A437
1.6.1.6.1	>>>>>	Coding Scheme Designator	(0008,0102)	SH	0004	SRT
1.6.1.6.1	>>>>>	Code Meaning	(0008,0104)	LO	0008	Maximum
	%enditem					
	%endseq					
	%enditem					
	%item					
1.6.1.6.2	>>>>	Relationship Type	(0040,a010)	CS	0010	HAS CONCEPT MOD
1.6.1.6.2	>>>>	Value Type	(0040,a040)	CS	0004	TEXT
1.6.1.6.2	>>>>	Concept Name Code Sequence	(0040,a043)	SQ	ffffff	
	%item					
1.6.1.6.2	>>>>>	Code Value	(0008,0100)	SH	0006	111001
1.6.1.6.2	>>>>>	Coding Scheme Designator	(0008,0102)	SH	0004	DCM
1.6.1.6.2	>>>>>	Code Meaning	(0008,0104)	LO	000e	Algorithm Name
	%enditem					
	%endseq					
1.6.1.6.2	>>>>	Text Value	(0040,a160)	UT	0022	Descriptive Statistics Calculator
	%enditem					
	%item					
1.6.1.6.3	>>>>	Relationship Type	(0040,a010)	CS	0010	HAS CONCEPT MOD
1.6.1.6.3	>>>>	Value Type	(0040,a040)	CS	0004	TEXT
1.6.1.6.3	>>>>	Concept Name Code Sequence	(0040,a043)	SQ	ffffff	
	%item					
1.6.1.6.3	>>>>>	Code Value	(0008,0100)	SH	0006	111003
1.6.1.6.3	>>>>>	Coding Scheme Designator	(0008,0102)	SH	0004	DCM
1.6.1.6.3	>>>>>	Code Meaning	(0008,0104)	LO	0012	Algorithm Version
	%enditem					
	%endseq					
1.6.1.6.3	>>>>	Text Value	(0040,a160)	UT	0004	1.0
	%enditem					
	%endseq					
	%enditem					
	%item					

SR Tree Depth	Nesting	Attribute	Tag	VR	VL (hex)	Value
1.6.1.7	>>>	Relationship Type	(0040,a010)	CS	0008	CONTAINS
1.6.1.7	>>>	Value Type	(0040,a040)	CS	0004	NUM
1.6.1.7	>>>	Concept Name Code Sequence	(0040,a043)	SQ	ffffff	
	%item					
1.6.1.7	>>>>	Code Value	(0008,0100)	SH	0006	126401
1.6.1.7	>>>>	Coding Scheme Designator	(0008,0102)	SH	0004	DCM
1.6.1.7	>>>>	Code Meaning	(0008,0104)	LO	0006	SUVbw
	%enditem					
	%endseq					
1.6.1.7	>>>	Measured Value Sequence	(0040,a300)	SQ	ffffff	
	%item					
1.6.1.7	>>>>	Measurement Units Code Sequence	(0040,08ea)	SQ	ffffff	
	%item					
1.6.1.7	>>>>>	Code Value	(0008,0100)	SH	000c	g/ml{SUVbw}
1.6.1.7	>>>>>	Coding Scheme Designator	(0008,0102)	SH	0004	UCUM
1.6.1.7	>>>>>	Code Meaning	(0008,0104)	LO	0026	Standardized Uptake Value body weight
	%enditem					
	%endseq					
1.6.1.7	>>>>	Numeric Value	(0040,a30a)	DS	000e	2.329186593407
	%enditem					
	%endseq					
1.6.1.7	>>>	Content Sequence	(0040,a730)	SQ	ffffff	
	%item					
1.6.1.7.1	>>>>	Relationship Type	(0040,a010)	CS	0010	HAS CONCEPT MOD
1.6.1.7.1	>>>>	Value Type	(0040,a040)	CS	0004	CODE
1.6.1.7.1	>>>>	Concept Name Code Sequence	(0040,a043)	SQ	ffffff	
	%item					
1.6.1.7.1	>>>>>	Code Value	(0008,0100)	SH	0006	121401
1.6.1.7.1	>>>>>	Coding Scheme Designator	(0008,0102)	SH	0004	DCM
1.6.1.7.1	>>>>>	Code Meaning	(0008,0104)	LO	000a	Derivation
	%enditem					
	%endseq					
1.6.1.7.1	>>>>	Concept Code Sequence	(0040,a168)	SQ	ffffff	
	%item					

SR Tree Depth	Nesting	Attribute	Tag	VR	VL (hex)	Value
1.6.1.7.1	>>>>	Code Value	(0008,0100)	SH	0008	R-00317
1.6.1.7.1	>>>>	Coding Scheme Designator	(0008,0102)	SH	0004	SRT
1.6.1.7.1	>>>>	Code Meaning	(0008,0104)	LO	0004	Mean
	%enditem					
	%endseq					
	%enditem					
	%item					
1.6.1.7.2	>>>>	Relationship Type	(0040,a010)	CS	0010	HAS CONCEPT MOD
1.6.1.7.2	>>>>	Value Type	(0040,a040)	CS	0004	TEXT
1.6.1.7.2	>>>>	Concept Name Code Sequence	(0040,a043)	SQ	ffffff	
	%item					
1.6.1.7.2	>>>>	Code Value	(0008,0100)	SH	0006	111001
1.6.1.7.2	>>>>	Coding Scheme Designator	(0008,0102)	SH	0004	DCM
1.6.1.7.2	>>>>	Code Meaning	(0008,0104)	LO	000e	Algorithm Name
	%enditem					
	%endseq					
1.6.1.7.2	>>>>	Text Value	(0040,a160)	UT	0022	Descriptive Statistics Calculator
	%enditem					
	%item					
1.6.1.7.3	>>>>	Relationship Type	(0040,a010)	CS	0010	HAS CONCEPT MOD
1.6.1.7.3	>>>>	Value Type	(0040,a040)	CS	0004	TEXT
1.6.1.7.3	>>>>	Concept Name Code Sequence	(0040,a043)	SQ	ffffff	
	%item					
1.6.1.7.3	>>>>	Code Value	(0008,0100)	SH	0006	111003
1.6.1.7.3	>>>>	Coding Scheme Designator	(0008,0102)	SH	0004	DCM
1.6.1.7.3	>>>>	Code Meaning	(0008,0104)	LO	0012	Algorithm Version
	%enditem					
	%endseq					
1.6.1.7.3	>>>>	Text Value	(0040,a160)	UT	0004	1.0
	%enditem					
	%endseq					
	%enditem					
	%item					
1.6.1.8	>>>	Relationship Type	(0040,a010)	CS	0008	CONTAINS
1.6.1.8	>>>	Value Type	(0040,a040)	CS	0004	NUM
1.6.1.8	>>>	Concept Name Code Sequence	(0040,a043)	SQ	ffffff	
	%item					

SR Tree Depth	Nesting	Attribute	Tag	VR	VL (hex)	Value
1.6.1.8	>>>>	Code Value	(0008,0100)	SH	0006	126401
1.6.1.8	>>>>	Coding Scheme Designator	(0008,0102)	SH	0004	DCM
1.6.1.8	>>>>	Code Meaning	(0008,0104)	LO	0006	SUVbw
	%enditem					
	%endseq					
1.6.1.8	>>>	Measured Value Sequence	(0040,a300)	SQ	fffffff	
	%item					
1.6.1.8	>>>>	Measurement Units Code Sequence	(0040,08ea)	SQ	fffffff	
	%item					
1.6.1.8	>>>>>	Code Value	(0008,0100)	SH	000c	g/ml{SUVbw}
1.6.1.8	>>>>>	Coding Scheme Designator	(0008,0102)	SH	0004	UCUM
1.6.1.8	>>>>>	Code Meaning	(0008,0104)	LO	0026	Standardized Uptake Value body weight
	%enditem					
	%endseq					
1.6.1.8	>>>>	Numeric Value	(0040,a30a)	DS	0010	1.8828952323684
	%enditem					
	%endseq					
1.6.1.8	>>>	Content Sequence	(0040,a730)	SQ	fffffff	
	%item					
1.6.1.8.1	>>>>	Relationship Type	(0040,a010)	CS	0010	HAS CONCEPT MOD
1.6.1.8.1	>>>>	Value Type	(0040,a040)	CS	0004	CODE
1.6.1.8.1	>>>>	Concept Name Code Sequence	(0040,a043)	SQ	fffffff	
	%item					
1.6.1.8.1	>>>>>	Code Value	(0008,0100)	SH	0006	121401
1.6.1.8.1	>>>>>	Coding Scheme Designator	(0008,0102)	SH	0004	DCM
1.6.1.8.1	>>>>>	Code Meaning	(0008,0104)	LO	000a	Derivation
	%enditem					
	%endseq					
1.6.1.8.1	>>>>	Concept Code Sequence	(0040,a168)	SQ	fffffff	
	%item					
1.6.1.8.1	>>>>>	Code Value	(0008,0100)	SH	0008	R-10047
1.6.1.8.1	>>>>>	Coding Scheme Designator	(0008,0102)	SH	0004	SRT
1.6.1.8.1	>>>>>	Code Meaning	(0008,0104)	LO	0012	Standard Deviation
	%enditem					

SR Tree Depth	Nesting	Attribute	Tag	VR	VL (hex)	Value
	%endseq					
	%enditem					
	%item					
1.6.1.8.2	>>>>	Relationship Type	(0040,a010)	CS	0010	HAS CONCEPT MOD
1.6.1.8.2	>>>>	Value Type	(0040,a040)	CS	0004	TEXT
1.6.1.8.2	>>>>	Concept Name Code Sequence	(0040,a043)	SQ	ffffff	
	%item					
1.6.1.8.2	>>>>>	Code Value	(0008,0100)	SH	0006	111001
1.6.1.8.2	>>>>>	Coding Scheme Designator	(0008,0102)	SH	0004	DCM
1.6.1.8.2	>>>>>	Code Meaning	(0008,0104)	LO	000e	Algorithm Name
	%enditem					
	%endseq					
1.6.1.8.2	>>>>	Text Value	(0040,a160)	UT	0022	Descriptive Statistics Calculator
	%enditem					
	%item					
1.6.1.8.3	>>>>	Relationship Type	(0040,a010)	CS	0010	HAS CONCEPT MOD
1.6.1.8.3	>>>>	Value Type	(0040,a040)	CS	0004	TEXT
1.6.1.8.3	>>>>	Concept Name Code Sequence	(0040,a043)	SQ	ffffff	
	%item					
1.6.1.8.3	>>>>>	Code Value	(0008,0100)	SH	0006	111003
1.6.1.8.3	>>>>>	Coding Scheme Designator	(0008,0102)	SH	0004	DCM
1.6.1.8.3	>>>>>	Code Meaning	(0008,0104)	LO	0012	Algorithm Version
	%enditem					
	%endseq					
1.6.1.8.3	>>>>	Text Value	(0040,a160)	UT	0004	1.0
	%enditem					
	%endseq					
	%enditem					
	%endseq					
	%enditem					
	%endseq					
	%enditem					
	%endseq					

A.8 Overview of Data Types

DICOM data types are specified in Part 5 of the standard (PS3.5).

The AIM V4 data types are a subset of [ISO 21090], which are in turn based on [V3 DT R1]. The AIM V4 data types used are documented in [AIM v3 v4 changes] and [Extending AIM].

While a complete comparison of DICOM and [ISO 21090] data types, cardinality and optionality is beyond the scope of this mapping guide, some hints are given on topics that are relevant for transforming AIM instances and DICOM SR Measurement Reports.

The AIM V4 model uses the data types as specified in Table A.8-2 from [ISO 21090], of which only a subset are encountered in use cases described by this mapping. In XML encoded AIM instances, the data type is not explicitly encoded, though it is defined in the UML model.

Table A.8-1. ISO 21090 Data Types used in AIM V4

ISO 21090 Data Types	Description
BL	Boolean (two-valued logic). A BL value can be either true or false, or may have a nullFlavor.
CD	Concept Descriptor. A reference to a concept defined in an external code system, terminology or ontology, or an expression in some syntax defined by the referenced code system.
II	Instance Identifier. An identifier that uniquely identifies a thing or object. Instance identifiers are usually defined based on ISO object identifiers.
INT	Integer. No arbitrary limit is imposed on the range of integer numbers.
REAL	Fractional numbers. The typical representation is decimal.
ST	Character string. Shall have at least one character or else have a nullFlavor.
TS	Point in time. A quantity specifying a point on the axis of natural time. Most often represented as a calendar expression.

Additional data type mapping considerations include:

a. Optionality and nullFlavor

If the original AIM instance does not include values that are required or mandatory in DICOM SR TID 1500, fixed values are specified since empty values are not permitted in DICOM SR TEXT and CODE entries and omitting the Content Item would violate the template constraints. All nullFlavor values are treated as empty, except for numeric values.

b. Character Sets

DICOM provides information on the interpretation of text data types by specifying a default character set (ISO-IR 6) and "Specific Character Set" (0008,0005) values that are used if the Basic Graphic Set is expanded or replaced. For AIM, the XML declaration attribute "encoding" (overall document) and the attribute "charset" (for ST data type values) may be used to provide information on character sets. See the description of Specific Character Set in Section A.6.1.1.11 "Mapping of DICOM SOP Common Module".

c. Character strings

In general, ST text value attributes in AIM XML elements are mapped to DICOM Text Value (0040,A160) of value type TEXT (with a VR of Unlimited Text (UT)) in the SR Content Tree. No maximum length is specified for AIM elements and attributes.

Some text value attributes in AIM XML elements are mapped to attributes in the DICOM header, and DICOM length limits may apply to character strings such as Long String (LO), e.g., Patient ID.

d. Identifiers

Unique identifiers in AIM V4 are encoded as the root attribute of an XML element (aim:uniqueIdentifier/@root), which has an II data type, and are mapped to the DICOM UI VR, which is limited to 64 bytes.

e. Codes

Codes in AIM V4 are encoded as attributes of the aim:typeCode XML element and are mapped as specified in Table A.8-2 below for the [ISO 21090] code data type (CD). The code and codeSystemName attributes are encountered as attributes of the aim:typeCode XML element, but the displayName is the value attribute of a child element, aim:typeCode/iso:displayName/@value. Note that codeSystem (Coding Scheme UID) is usually not sent, even though it is required by [ISO 21090]. DICOM also supports other Attributes for encoding code values that exceed 16 characters in length.

Table A.8-2. Mapping between DICOM Basic Code Attributes and AIM ISO 21090 Code Data Types (CD)

DICOM Attribute and VR		AIM Element and Attribute and ISO 21090 Data Type	
Code Value (0008,0100)	SH	aim:typeCode/@code	CD.characterstring
Coding Scheme UID (0008,0x010C)	UI	aim:typeCode/@codeSystem	CD.characterstring
Coding Scheme Designator (0008,0102)	SH	aim:typeCode/@codeSystemName	CD.characterstring
Coding Scheme Version (0008,0103)	SH	aim:typeCode/@codeSystemVersion	CD.characterstring
Code Meaning (0008,0104)	LO	aim:typeCode/iso:displayName/@value	CD.ST

f. Date and Time

- The AIM V4 XML element aim:dateTime/@value attribute corresponds to the ISO 21090 TS data type, and is mapped to the DICOM DateTime (DT) VR, or the combination of separate Date (DA) and Time (TM) Attributes.
- DICOM DT matches TS except for the number of decimal places of fractional seconds (6 for DT versus 4 for TS).
- DICOM DA matches the TS part YYYYMMDD (Y=Year, M=Month, D=Day), except that TS may be missing DD or MMDD.
- DICOM TM matches the TS part HHMMSS.UUUUUU (H=Hour, M=Minute, S=Second, U=Fractional Second) except for the number of decimal places of fractional seconds (6 for DT versus 4 for TS).
- If available, the DICOM Timezone Offset From UTC (0008,0201) used for DA or TM data types may be populated using time zone offset values from the ISO 21090 TS value.
- ISO TS allows for separators; these need to be removed for conversion to DT, DA and TM.

g. Person Names

- DICOM Person Name (PN) shall be mapped from [ISO 21090] data type Person Name (PN) as described in Table A.8-3.

Table A.8-3. Mapping between DICOM Person Name (PN) and ISO 21090 Data Type Person Name (PN)

DICOM Person Name (PN)	ISO 21090 Data Type: Person Name (PN)
<family_name_complex>	Family Part type
<given_name_complex>	Given Part type
<middle_name>	Given Part type - order of parts matters
<name_suffix>	Suffix Part type
<name_prefix>	Prefix Part type

- [ISO 21090] PN may contain multiple given names. DICOM PN Middle Name shall be mapped to [ISO 21090] PN Given Name Part type.

Example A.8-1. Person Name Example

John Robert Morrison, Ph.D. "Morrison^John Robert^^Ph.D." [One family name; two given names; no middle name; no prefix; one suffix] can be represented as a [ISO 21090] Person Name (PN) in the following way:

```
<name>
  <given>John</given>
  <given>Robert</given>
```

```

1 <family>Morrison</family>
2 <suffix>Ph.D.</suffix>
3 </name>
    
```

- The following [ISO 21090] PN use codes may be used to represent multi-part DICOM person names: ABC (Alphabetic), IDE (Ideographic), SYL (Phonetic).

Example A.8-2. HL7 V3 Multi-Part Person Name Example

```

7 <name use="ABC">
8   <family>KIMURA</family>
9   <given>MICHIO</given>
10 </name>
11 <name use='IDE'>
12   <family>木村</family>
13   <given>道男</given>
14 </name>
15 <name use="SYL">
16   <family>きむら</family>
17   <given>みちお</given>
18 </name>
    
```

h. Numeric Measurements

DICOM Numeric Measurement value types shall be mapped from the [ISO 21090] data types as specified in Table A.8-4.

Table A.8-4. Mapping between DICOM Numeric Measurement Value Types and ISO 21090 Data Types

DICOM PS3.3, PS3.5 and PS3.16: Numeric Measurement (NUM) Value Type		AIM Path and ISO 21090 Data Type	
Measured Value Sequence (0040,A300) > Concept Name Code Sequence (0040,A043)	Code Sequence Macro	CalculationEntity/typeCode[1]	CD
Measured Value Sequence (0040,A300) > Numeric Value (0040,A30A)	DS	CalculationEntity/calculationResultCollection/ CalculationResult/@value CalculationEntity/calculationResultCollection/ CalculationResult/calculationDataCollection/ CalculationData/@value	ST
Measured Value Sequence (0040,A300) > Measurement Units Code Sequence (0040,08EA)	Code Sequence Macro	CalculationEntity/calculationResultCollection/ CalculationResult/unitOfMeasure	ST
Numeric Value Qualifier Code Sequence (0040,A301)	Code Sequence Macro	CalculationEntity/calculationResultCollection/ CalculationResult/calculationDataCollection/ CalculationData/@value	ST

The [ISO 21090] PQ data type is not used in AIM.

The Concept Name of the measurement is usually pre-coordinated in a single CalculationEntity/typeCode entry. If there is more than one CalculationEntity/typeCode, the first is assumed to be the primary concept and the others may be modifiers that, if recognized as such, may be mapped to method and derivation, or if otherwise recognized and name-value pair of concepts can be constructed can be encoded as generic modifiers, but otherwise have to be ignored.

The Numeric Value may be found as the single value of a CompactCalculationResult (i.e., value child of CalculationResult) or the first value of an ExtendedCalculationResult (i.e., nested within calculationResultCollection). This can give rise to a difference in representation in a round trip conversion.

Units of measurement shall be converted from a text string (ST) to a Coded Sequence entry using the UCUM Code Values and "UCUM" as the Coding Scheme Designator (in AIM, CalculationResult/unitOfMeasure is defined as "A string representation of UCUM unit for the value of the calculation").

The AIM CalculationData/@value shall be assumed to be in the US English locale (i.e., periods are used as the decimal point, not commas, etc.).

The length of the AIM CalculationData/@value ST is not limited, but the DICOM DS value representation is limited to 16 characters. Values of CalculationData/@value that are too long shall be truncated or rounded to fit in an implementation-dependent manner.

The CalculationResult/dataType (e.g., Double, Integer) is not encoded in the DICOM mapping, since all DICOM SR numeric values are encoded as a Decimal String (DS), so in a round trip from AIM to DICOM and back to AIM will not be recovered (i.e., will always be encoded as Double). For the use cases for this mapping, it is likely that all measurements will be Double anyway.

DICOM allows the Measured Value Sequence (0040,A300) to be sent zero length (empty) if there is no value. In such cases the Numeric Value Qualifier Code Sequence (0040,A301) may be used in DICOM to send a code indicating why, either because of an invalid floating point result (e.g., (114000, DCM, "Not a number") corresponding to [IEEE 754] NaN), or for more general reasons (e.g., (114006, DCM, "Measurement failure")). See PS3.16 CID 42 Numeric Value Qualifier. Table A.8-4 indicates that a non-numeric CalculationData/@value may be mapped to Numeric Value Qualifier Code Sequence (0040,A301). Various possible mappings of AIM string values to a subset of DICOM codes corresponding to [IEEE 754] are defined in Table A.8-5. These are based on the:

- Java Double.toString(double) definition (see <https://docs.oracle.com/javase/8/docs/api/java/lang/Double.html#toString-double->)
- [XSD Datatypes]
- [ISO 21090]

No similar standard C or C++ mapping is known to exist (e.g., for libc dtostr() or sprintf()). Other languages offer some flexibility (e.g., Python supports case insensitive variants of "NaN" and "Infinity", the latter with or without a sign; see <http://docs.python.org/3/library/functions.html#float>). For JavaScript, see <https://tc39.github.io/ecma262/#sec-tostring-applied-to-the-number-type>, <https://tc39.github.io/ecma262/#sec-parsefloat-string> and <https://tc39.github.io/ecma262/#sec-number.parsefloat>. The table describes a subset of possible values, the mapping may not be exact (e.g., the definitions of NaN may differ), the mapping is ambiguous (since AIM does not define which string source to use), and the mapping of other values is undefined.

Table A.8-5. Mapping between DICOM Numeric Value Qualifier Code Sequence and AIM ST

DICOM Code	Java String	XML Schema	ISO 21090 Null Flavor
(114000, DCM, "Not a number")	NaN	NaN	
(114001, DCM, "Negative Infinity")	-Infinity	-INF	NINF
(114002, DCM, "Positive Infinity")	Infinity	INF	PINF

i. Image and segmentation references

DICOM image references may be mapped as specified in Table A.8-6.

Table A.8-6. DICOM Image references to AIM Path

DICOM PS3.3, PS3.5 and PS3.16: Image Reference (IMAGE) Value Type		AIM Path and ISO 21090 Data Type	
Referenced SOP Sequence > Referenced SOP Class UID	UI	/ImageAnnotationCollection/imageAnnotations/ImageAnnotation/imageReferenceEntityCollection/ImageReferenceEntity/imageStudy/imageSeries/imageCollection/Image[sopInstanceUid/@root=imageReferenceUid/@root]/sopClassUid/@root	II
Referenced SOP Sequence > Referenced SOP Instance UID	UI	imageReferenceUid/@root	II
Referenced SOP Sequence > Referenced Frame Number	IS	referencedFrameNumber/@value	INT

An image reference in the AIM tree locally consists of the SOP Instance UID only, without SOP Class, which is described elsewhere in the tree in the imageReferenceEntityCollection (which, similar to the DICOM Current Requested Procedure Evidence Sequence or Pertinent Other Evidence Sequence, also contains the Study and Series level information). Hence the use of the predicate "sopInstanceUid/@root=\$sopInstanceUID" in the path in the table.

DICOM segmentation references may be mapped as specified in Table A.8-7.

Table A.8-7. DICOM Segmentation references to AIM Path

DICOM PS3.3, PS3.5 and PS3.16: Image Reference (IMAGE) Value Type		AIM Path and ISO 21090 Data Type	
Referenced SOP Sequence > Referenced SOP Class UID	UI	SegmentationEntity/sopClassUid/@root	II
Referenced SOP Sequence > Referenced SOP Instance UID	UI	SegmentationEntity/sopInstanceUid/@root	II
Referenced SOP Sequence > Referenced Segment Number	US	SegmentationEntity/segmentNumber/@value	INT

The SOP Class UID is included locally in the AIM tree with the reference, rather than being factored out into the imageReferenceEntityCollection, in which it is not present.

Ideally, all segmentation references would be included in either Current Requested Procedure Evidence Sequence or Pertinent Other Evidence Sequence as appropriate; however there is insufficient information in the AIM 4.0 model to support this; i.e., the Study and Series Instance UIDs are absent, and cannot safely be assumed to be those of any related images.

The reference to the original image that was segmented, which may be encoded in SegmentationEntity/referencedSopInstanceUid/@root may be encoded in a separate Content Item if supported by the template (e.g., TID 1410, TID 1411) in (121233, DCM, "Source image for segmentation").